

# TOTAL RANGE

01	<b>Index</b>
02	<b>Service and Systems</b>
03	<b>Chemical Technical Products</b>
04	<b>Fasteners / Fittings</b>
05	<b>Anchor and Plug Systems</b>
06	<b>Fire Protection Systems</b>
07	<b>Material Processing</b>
08	<b>General Tools / Equipment</b>
09	<b>master® Power Tools</b>
10	<b>ORSY® Assortments and Workshop Equipment</b>
11	<b>Work Protection</b>
12	<b>Construction Accessories</b>
13	<b>Electrical</b>
14	<b>Sanitary</b>
15	<b>Automotive / Cargo Accessories and Spare Parts</b>

## 06 Fire Protection Systems

Systems / performance overview	1383 - 1391
Fire protection systems	1392 - 1416
Fire protection products	1417 - 1472
Fire protection systems online / software / services	1473

# FIRE-PROTECTION SYSTEMS



- Applications
- Solutions
- Systems
- Products

Patented guidance system

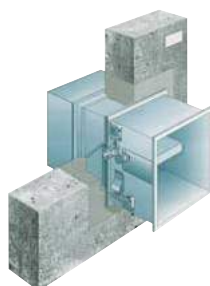
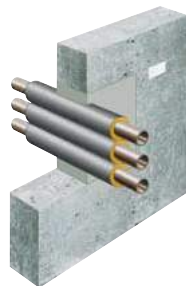
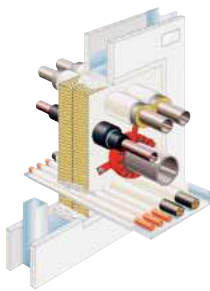
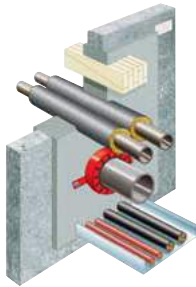

# SYSTEM MATRIX

The system matrix applies to uses in all industries. It shows the exact allocation of the Würth fire protection systems to the surfaces used today in building technology.

The system matrix has the same structure as the application matrix. It shows the same decisive parameters for fire-protection partitions under the assignment of the color coding.

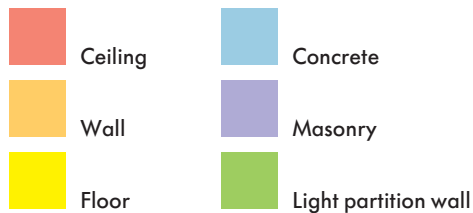

The fire-protection systems assigned to the respective surface can always be used here. It depends on your partition location – ceiling, wall, floor, – your application – cable ducts, pipe ducts, joint seals and cable and pipe ducts – as to which fire-protection system you should select.

The letter in front of the system designation directs you to the detailed system description.

In the fire-protection system specifications, a differentiation is now made between

**– new installation** and

**– retrofitting**.

The products recommended by Würth are shown under this.

The number in front of the product designation directs you (product specification) to the detailed product description.

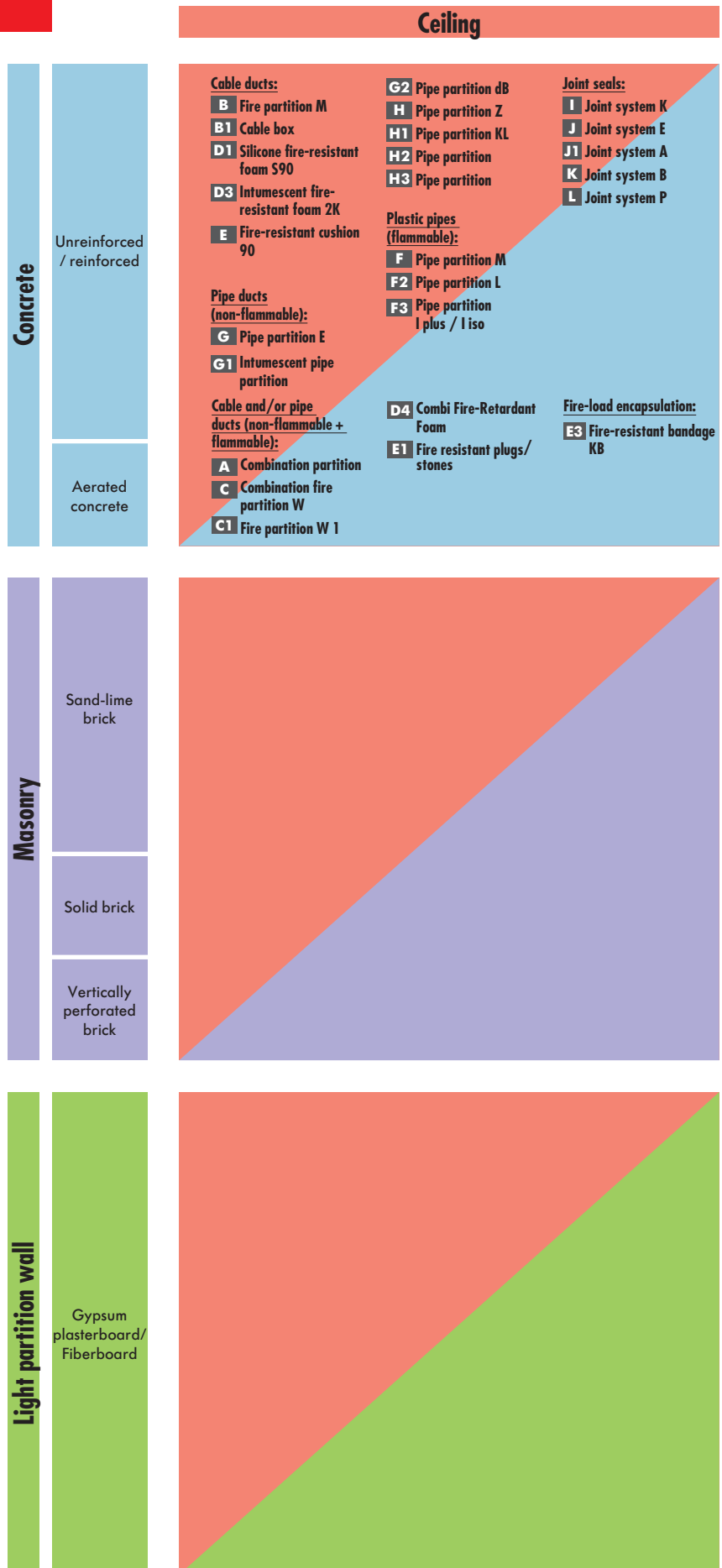

## Wall

## Floor

**Cable ducts:**

- W** Fire partition M
- B1** Cable box
- D1** Silicone fire-resistant foam S90
- D3** Intumescent fire-resistant foam 2K
- E** Fire-resistant cushion 90

**Pipe ducts (non-flammable):**

- G** Pipe partition E

**Cable and/or pipe ducts (non-flammable + flammable)**

- A** Combination partition
- C** Combination fire partition W

**Joint seals:**

- I** Joint system K
- J** Joint system E
- J1** Joint system A
- K** Joint system B
- D** Joint system P
- L1** Joint system B1

**Intumescent pipe partition**

- G1** Intumescent pipe partition
- H** Pipe partition Z
- H1** Pipe partition KL
- H2** Pipe partition KL
- H3** Pipe partition KL

**Plastic pipes (flammable):**

- F** Pipe partition M
- F2** Pipe partition L
- F3** Pipe partition I plus/I iso

**Combi fire-resistant foam**

- D4** Combi fire-resistant foam

**Fire-resistant plugs/stones**

- E1** Fire-resistant plugs/stones

**Fire-load encapsulation:**

- E3** Fire-resistant bandage KB
- E4** Fire-resistant duct 130 / 160 / 190 / 1120



**C1** Fire partition W 1

**Cable ducts:**

- W** Fire partition M
- B1** Cable box
- D1** Silicone fire-resistant foam S90
- D3** Intumescent fire-resistant foam 2K
- E** Fire-resistant cushion 90

**Pipe ducts (non-flammable):**

- G** Pipe partition E

**Cable and/or pipe ducts (non-flammable + flammable)**

- M** Combination partition
- C** Combination fire partition W

**Joint seals:**

- I** Joint system K
- J** Joint system E
- J1** Joint system A
- K** Joint system B
- D** Joint system P
- L1** Joint system B1

**Intumescent pipe partition**

- G1** Intumescent pipe partition
- H** Pipe partition Z
- H1** Pipe partition KL
- H2** Pipe partition KL
- H3** Pipe partition KL

**Plastic pipes (flammable):**

- F** Pipe partition M
- F2** Pipe partition L
- F3** Pipe partition I plus/I iso

**Combi fire-resistant foam**

- D4** Combi fire-resistant foam

**Fire-resistant plugs/stones**

- E1** Fire-resistant plugs/stones

**Fire-load encapsulation:**

- E3** Fire-resistant bandage KB
- E4** Fire-resistant duct 130 / 160 / 190 / 1120

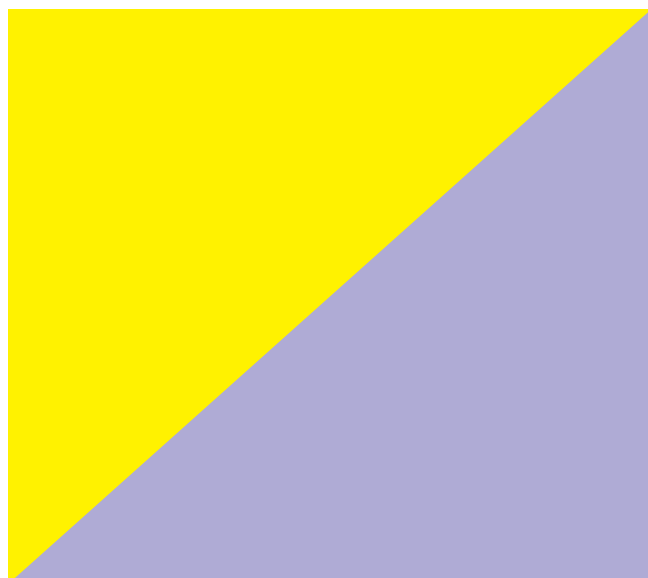

**C1** Fire partition W 1

**Cable ducts:**

- B1** Cable box
- E** Fire-resistant cushion 90

**Pipe ducts:**

- G1** Intumescent pipe partition
- H2** Pipe partition KL
- H3** Pipe partition KL

**Plastic pipes (flammable):**

- F** Pipe partition M
- F2** Pipe partition L
- F3** Pipe partition I plus/I iso

**Cable and/or pipe ducts (non-flammable + flammable)**

- C** Combination fire partition W
- C1** Fire partition W 1

**Intumescent fire-resistant foam 2K**

- D3** Intumescent fire-resistant foam 2K

**Combi fire-resistant foam**

- D4** Combi fire-resistant foam

**Fire-resistant plugs/stones**











- E1** Fire-resistant plugs/stones

**Fire-load encapsulation:**

- E3** Fire-resistant bandage KB
- E4** Fire-resistant duct 130 / 160 / 190 / 1120



## FIRE-PROTECTION SYSTEMS / PERFORMANCE OVERVIEW











		Fire-protection system specification	Application criterion				
			Sub-surface			Required	
			Concrete	Masonry	Gypsum plasterboard	wall thickness in mm	ceiling thickness in mm
<b>System A</b>	<b>Combination partition Hard partition Fire-resistant mortar</b>		x			100	150
				x		100	
					-		
<b>System B</b>	<b>Fire partition M S120 Hard partition Fire resistant mortar</b>		x			240	200
				x		240	
					-		
<b>System B1</b>	<b>Cable box <u>Sheet-steel housing with internal intumescent inserts</u></b>		x			100 (125)	150
				x		100 (125)	
					x	100 (125)	
<b>System C</b>	<b><u>Combination Fire Partition W</u> Soft partition/plate partition Fire-resistant coating</b>		x			100	150
				x		100	
					x	100	
<b>System C1</b>	<b><u>Fire partition W1</u> Soft partition/plate partition Fire-resistant coating</b>		x			100	150
				x		115	
					x	100	
<b>System D1</b>	<b><u>Silicone Fire-resistant foam S90 / R90</u></b>		x			150	150
				x		150	
					x (R90)	100	
<b>System D2</b>	<b><u>Intumescent cable partition</u> Intumescent fireproof seal</b>		x			150	150
				x		150	
					-		
<b>System D3</b>	<b><u>Intumescent fire-resistant foam 2 K</u></b>		x			100	150
				x		100	
					x	100	
<b>System D4</b>	<b><u>Combi fire-resistant foam</u></b>		x			100	150
				x		100	
					x	100	
<b>System E</b>	<b><u>Fire-resistant cushion 90</u> Flexible partition</b>		x			100	150
				x		100	
					x	100	
<b>System E1</b>	<b><u>Fire-resistant plugs / stones</u> Flexible partition</b>		x			100	150
				x		100	
					x	100	

xx = especially suitable x = suitable - = not suitable

## FIRE-PROTECTION SYSTEMS / PERFORMANCE OVERVIEW

Application criterion		Maximum opening in carcass		Fire resistance duration	Notes on application		Special features			Consumption approx.
in mm	in mm	Width x height in cm	Width x length in cm	Min.	Ready-to-use product	Dust-free installation possible	Especially for frequent additions	Intumescent	Removable/Reusable	
150	150	100 x 200 or 200 x 100	100 x ∞	S 90	-	-	x	-	-	150 kg per m <sup>2</sup>
150										
240	240	150 x 350 (150 x 250)	70 x ∞	S 120 (S90)	-	-	x	-	-	240 kg (175 kg) per m <sup>2</sup>
240										
280 (125)	280	-	-	S 90	x	x	xx	x	x	
280 (125)										
280 (125)										
100	100	120 x 200	150 x ∞	S 90	-	-	x	x	-	2 kg per m <sup>2</sup> of fire-retardant coating
100		120 x 200								
100		125 x 170								
80	80	120 x 200	40 x ∞	S 90	-	-	x	x	-	2 kg per m <sup>2</sup> of fire-retardant coating
80		120 x 200								
80		80 x 50								
150	150	10 cm high 50 cm wide 11 cm dia.	10 x 50 cm or 11 cm dia.	S 90	x	x	-	-	-	
150										
150	150	max. 100 cm <sup>2</sup> round or rectangular		S 90	x	-	x	x	-	1-2 cartridges per partition 50% filled
150										
150	150/200	20 x 20 Ø 20 cm	20 x 20 Ø 20 cm	S 90	x	x	-	x	-	380 ml cartridge with yield of approx 2 liters.
200/250	200/250	Combination partition, 450 x 450 mm Cable partition, 270 x 270 mm 300 mm dia.		EI 30 - EI 120	x	x	x	x	-	380 ml cartridge with yield of up to 2 liters
200/250	200/250									
200/250	200/250									
300	300	106 x 150	60 x ∞	S 90	x	x	xx	x	x	90 small, 40 large cushions per m <sup>2</sup>
300	300									
300										
Fire-protection stopper 200 to 220 mm Fire protection bricks 220 mm		31 cm dia. for fire protection plugs 100 x 150	31 cm dia. for fire protection bricks 50 x ∞	S 90	x	x	x	x	-	

## FIRE-PROTECTION SYSTEMS / PERFORMANCE OVERVIEW







		Fire-Protection Systems Specification	Application criterion			required	
			Substrate			Wall thickness in mm	Ceiling thickness in mm
			Concrete	Masonry	Gypsum plasterboard		
<b>System E3</b>	<b>KB Fire Protection Bandage</b> <b>Cable bandage which foams up in case of fire</b>		x			Fire protection jacket for preventing fire from occurring and to prevent fire from being passed on by cables and cable systems.	
<b>System E4</b>	<b>Fire-Protection Duct</b> <b>I 30 / I 60 / I 90 / I 120</b>		x			-	
<b>System F</b>	<b>Pipe Partition M</b>		x			F 90 wall/ceiling	
<b>System F2</b>	<b>Pipe Partition M</b> <b>Lightweight</b>		x			F 90 wall/ceiling	
<b>System F3</b>	<b>Pipe Partition I plus/I iso</b> <b>inside packing of an intumescent strip</b>		x			F 90 wall/ceiling, light partition wall in preparation	
<b>System G</b>	<b>Pipe Partition E</b> <b>Elastic fire protection seal</b>		x			F 90 wall/ceiling	
<b>System G1</b>	<b>Intumescent pipe partition</b>		x			80	80
<b>System G2</b>	<b>Pipe Partition dB Intumescent</b> <b>Ceiling partition for non-flammable pipes</b>		x			-	F 90m ceiling 150 mm
<b>System H</b>	<b>Pipe Partition Z</b> <b>Hard partition/pipe insulation</b> <b>Fireproof cement</b>		x			F 90 wall/ceiling	
<b>System H1</b>	<b>Pipe Partition KL</b> <b>Hard partition/pipe insulation</b> <b>Refrigeration piping</b>		x			150	100
<b>System H2</b>	<b>Pipe Partition</b> <b>Intumescent mat plus</b>		x			150	150

xx = particularly suitable x = suitable - = not suitable

## FIRE-PROTECTION SYSTEMS / PERFORMANCE OVERVIEW

Application criterion		Maximum opening in carcass		Fire resistance time	Notes on application		Special features			Consumption approx.
in mm	in mm	Width x height in cm	Width x length in cm	Min.	Ready-to-use product	Dust-free installation possible	Especially for frequent reloading	Intumescent	Removable/Reusable	
The permissibility of application on cables and cable systems along rescue routes is to be decided upon in individual cases by the respective building supervisory board, e.g. in conjunction with the fire protection concept.				Over at least 90 min.	x	x	x	x	x	Dependent on the cable conduit size
-		Wall ducts in solid and light partition walls are possible.		I 30/I 60/I 90/I 120	x	x	x	x	x	Dependent on the cable assignment
Flushwith wall	Flushwith ceiling	-	-	R 90	x	x	-	x	x	
Flushwith wall	Flushwith ceiling	-	-	R 90	x	x	-	x	x	
Flushwith wall	Flushwith ceiling	-	-	R 90	x	x	-	x	-	Example Version b : Pipe dia. 110, 139 cm, 4 coils
Flushwith wall	Flushwith ceiling	for pipes up to DN 150 mm		F 90	x	x	-	-	-	1/2 cartridges for opening 100 mm dia. Joint width 20 mm
Flushwith wall	Flushwith ceiling	Circumferential joint gap ≤ 15 mm		F 90	x	x	-	x	-	1/2 cartridges for opening 100 mm dia. Joint width 20 mm
-	Flushwith ceiling	For pipes up to DN 125 mm		F 90	x	-	-	x	x	Dependent on pipe diameter
Flushwith wall	Flushwith ceiling	-	-	F 90	-	-	-	-	-	Dependent on pipe dia., insulation dia., carcass opening
Spacing of pipes to each other ≥ 100 mm				F 90	x	-	-	-	-	
Spacing of insulated pipes ≥ 0 mm possible				F 90	x	x	-	x	-	Dependent on pipe diameter

## FIRE-PROTECTION SYSTEMS/PERFORMANCE OVERVIEW

Fire-Protection Systems Specification		Application criterion					
		Substrate			required		
		Concrete	Masonry	Gypsum plasterboard	Wall thickness in mm	Ceiling thickness in mm	
xx = particularly suitable x = suitable - = not suitable							
<b>System H3</b>	<b>Pipe partition</b> <b>Intumescent strips plus</b>		x			150	150
				x		150	
					x	100 (R 30/75)	
<b>System I</b>	<b>Joint System K</b> <b>Hard partition fireproof cement</b>		x			F 90 wall/ceiling	
				x			
					-		
<b>System J</b>	<b>Joint System E</b> <b>Elastic fire protection seal</b>		x			F 90 wall/ceiling	
				x			
					-		
<b>System J1</b>	<b>Joint System A</b> <b>Acrylic fire-resistant joint sealer</b>		x			F 30, F 60, F 90 Wall and ceiling	
				x			
					-		
<b>System D</b>	<b>Joint System P</b> <b>Pre-compressed sealing tape, impregnated polyurethane foam</b>		x			F 130F 120 wall/ceiling	100
				x			150
					-		
<b>System L1</b>	<b>Joint System B1</b> <b>(flame-retardant)</b> <b>FZ plus fire-resistant foam</b>		x			Requirements B1 for building materials	
				x			
					-		

## FIRE-PROTECTION SYSTEMS/PERFORMANCE OVERVIEW

Application criterion		Maximum opening in carcass		Fire resistance duration	Notes on application		Special features			Consumption approx.
Wall	Ceilings	Wall	Ceiling							
in mm	in mm	Width x height in cm	Width x length in cm	Min.	Ready-to-use product	Dust-free installation possible	Especially for frequent reloading	Intumescent	Removable/Reusable	
Spacing of insulated pipes $\geq 0$ mm possible				F 90 (F 30)	x	x	-	x	-	Dependent on pipe diameter
See construction permit of fire-protection hatch manufacturer				F 90	-	-	-	-	-	Dependent on joint width, hatch size, wall thickness
Flushwith wall	Flushwith ceiling	max. joint width 30 mm		F 90	x	x	-	-	-	Dependent on joint width, joint depth
Flushwith wall	Flushwith ceiling	max. joint width 30 mm		F 90	x	x	-	-	-	Dependent on joint width
Flushwith wall	Flushwith ceiling	max. joint width 40 mm		F 120	x	x	-	-	-	Dependent on joint width and hardened fire resistance duration
For joints and for T 30 fire protection doors from Neuform-Türenwerk				B1 or T 30-/RS	x	x	-	-	-	600-ml-cartridge up to 20 liter yield

**System  
A**

# Combination Partition



**Partitioning system of special mortar for routing through cables and flammable or non-flammable pipes.**

**Processing permitted by intensively trained specialised personnel only!  
Würth offers fire protection seminars for users.**

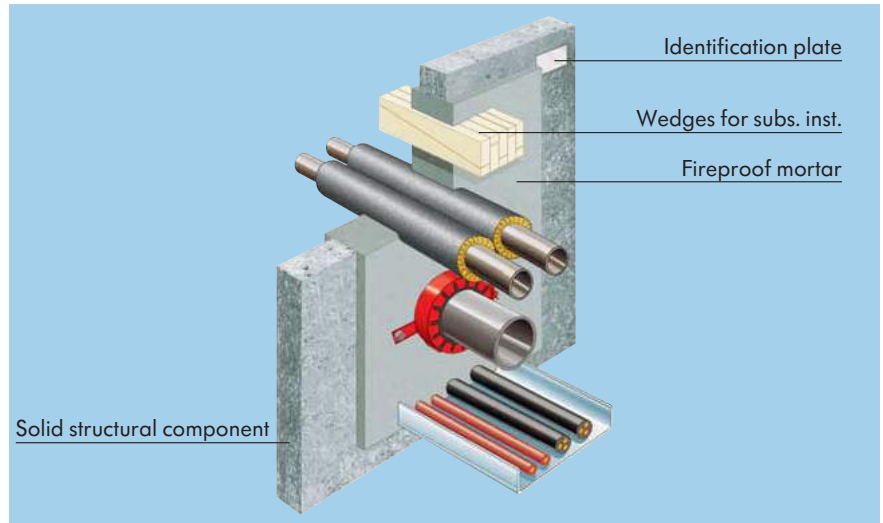

**The following are required for initial installation**

- 12** = Fireproof Mortar
- 21** = Fire-Protection Sleeve
- 42** = Mineral-Fibre Pipe Insulation
- 44** = Mineral-Fibre Insulation
- 71** = Wedges for Subsequent Installation

**The following are required for subsequent installation**

- 62** = Fireproof Filler

The products listed above can be found in the fire protection products specifications.

**Test reports and approvals** for the following applications

Wall and ceiling ducts  
S 90  
Z-19.15-1333

**Properties**

Seals off fire and combustion gases, temperature-reducing, seals off rooms, resistant to splash water, extinguishing water and ageing.

**Applications**

Both cables of all types and pipes of flammable and non-flammable materials may be routed through the partition.

**Notes**

- Additional cables can be routed through the partition material at any time, and wedges for later installation can be installed when producing the partition wall that simplify the addition of cables later.
- Cables installed at a later time must be sealed off with fireproof filler.

**Applications**

Fire endurance according to standard DIN 4102, Part 9	S 90
In walls and ceilings made of	concrete and masonry with the fire-resistance rating F 90
For cables and pipes	of all types
Maximum filling	60% of unfinished opening

**Dimensions**

Dimensions	S 90	Options for later additions	mm
Wall thickness	≥ 100 mm.	Mineral wool +	≥ 130
Ceiling thickness	≥ 150 mm.	Fireproof filler on both sides	≥ 10
Maximum unfinished opening in wall	1000 mm x 2000 mm	<b>Pipe insulation</b>	
Max. opening in carcass - ceiling	1000 mm (width) x length unlimited	Steel, stainless steel, cast iron	Thickness
<b>Partition thickness</b>	<b>S 90</b>	50	1 x 30 mm
Wall	≥ 150 mm	> 50 159	2 x 30 mm / 1 x 60 mm
		Copper pipes	Insulated length
			700 mm
			1000 mm

**System  
B**

# Fire Partition M



**Mineral-fibre free partition system of special mortar for all types of cables and lines.**

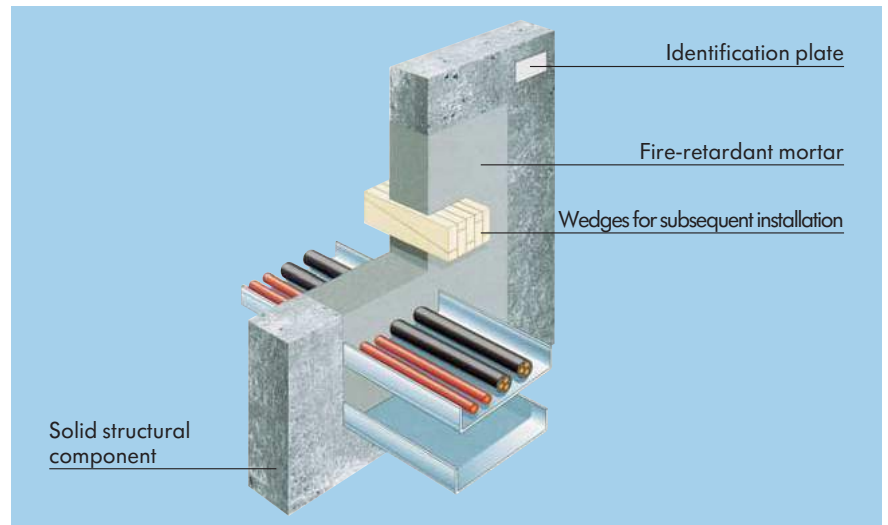

### The following are required for initial installation

- 12** = Fire-retardant mortar
- 71** = Wedges for subsequent installation

### The following are required for subsequent installation

- 62** = Fire-retardant filler

The products listed above can be found in the fire protection products specifications.

### Test reports and approvals for the following applications

Wall and ceiling ducts S 90 Z-19.15-1333	Wall and ceiling ducts S 120 Z-19.15-812
--	--

### Applications

For wall and ceiling duct of fire-resistance rating S 90 or S 120 according to DIN 4102, Part 9 for cables, cable bundles and cable tray systems.

### Notes

- Additional cables can be routed through the partition material at any time, and wedges for later installation can be installed when producing the partition wall that simplifies the addition of cables later.
- Cables installed at a later time must be sealed off with intumescent fire-retardant sealant or with fire-retardant filler.

### Applications

Fire endurance according to standard DIN 4102, Part 9	S 90 or S 120
In walls and ceilings of	concrete and masonry with the fire-resistance rating F 90
For cables	of all types
Maximum filling	60% of the opening in the carcass calculated for the cable cross-section

### Dimensions

Dimensions	S 90	S 120
Wall thickness	≥ 100 mm	≥ 240 mm
Maximum opening in the carcass	1000 x 2,000 mm	1500 x 3,500 mm
Ceiling thickness	≥ 150 mm	≥ 200 mm
Maximum opening in carcass	1000 mm, length is not limited	700 mm, length is not limited
Partition thickness	S 90	S 120
Wall	≥ 150 mm	≥ 240 mm
Ceiling	≥ 150 mm	≥ 240 mm
Area	as per opening in carcass	as per opening in carcass

# CABLE BOX

System  
**B1**

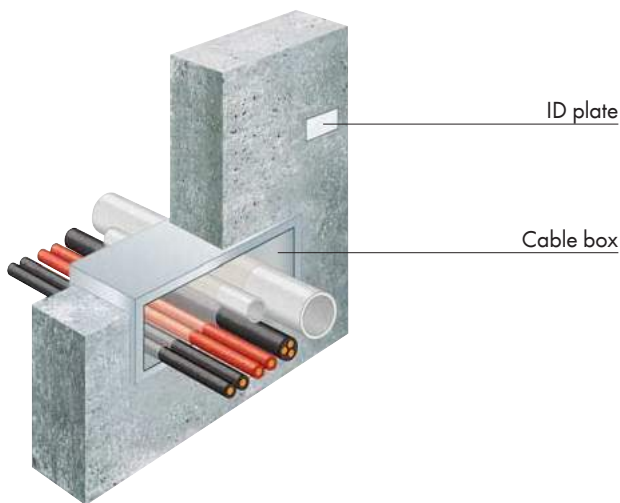

**Partition system for enclosing electrical cables, consisting of a sheet-metal housing with internal intumescent inlays.**  
**Variant EASY also with expanded-graphite strips**

### Required for new installation

- 11** = Fireproof Cement MG III
- 38** = Long or Short Cable Box  
Transparent Silicone Art. No. 0892 530 1  
PURlogic® EASY Foam Art. No. 0892 143

The products listed above can be found in the fire-protection product specifications.

### Test reports and approvals for the following applications

Short cable box type Wall ducts S 90/S 30 Z-19.15-1428	Long cable box type Wall and ceiling ducts S 90 Z-19.15-1429
---	---

### Areas of use

Cables and electrical lines may be routed through the cable partition. The cable box must be installed in min. 10 cm-thick solid walls, min. 15 cm-thick solid ceilings (long type) and in min. 10 cm-thick light stud partitions with steel sub-structure and planking made of gypsum-plasterboard fire-resistant panels or non-flammable cement or gypsum-bonded panels on both sides to at least fire-resistance class F 90 or F 30 (short type). Easy to retrofit, as no backfilling of the box interior is required; only smoke gas-proof sealing of the foam strip.

### Required for retrofitting

Transparent Silicone Art. No. 0892 530 1

Subsequent installation of the box is possible at any time by removing the top of the box.

### Notes

The cable box may be filled up to 100% with cables and electrical lines, waveguides, coaxial cables, bundled tubing, fiber-optic cables, electrical installation tubes and cable bundles.

Plastic tubes up to max. M 63 (long type) or M 40 (short type) are used for subsequent fitting. For more precise specifications, please refer to general construction permits Z-19.15-1428 and Z-19.15-1429.

Group arrangement					
Install. type	Arrangement	Dimensions (width x height)	Joint	Long type <sup>1)</sup>	Short type <sup>1)</sup>
Concreting of solid wall	≤ 3 boxes next to one another and 7 over one another	Wide sheet-steel housing ≤ 500 mm	≥ 15 mm	x	
	≤ 3 boxes next to one another and 2 over one another	Total ≤ 550 mm x 135 mm	≥ 15 mm		x
	≤ 3 boxes next to one another and 4 over one another	Wide sheet-steel housing > 500 mm	≥ 15 mm	x	
Concreting of light partition	≤ 3 boxes next to one another and 6 over one another	Wide sheet-steel housing ≤ 535 mm Total ≤ 535 mm x 605 mm	≥ 15 mm	x	
	≤ 3 boxes next to one another and 2 over one another	Total ≤ 550 mm x 135 mm	≥ 15 mm		x <sup>2)</sup>
Concreting of ceiling	≤ 3 boxes in front of one another and ∞ next to one another	-	≥ 15 mm	x	
Installation foam	≤ 2 boxes next to one another and 2 over one another	Wide sheet-steel housing ≤ 380 mm Total ≤ 380 mm x 240 mm	≤ 20 mm	x	
		Total ≤ 380 mm x 135 mm	≤ 20 mm		x

<sup>1)</sup> The spacing between groups must be at least 20 cm

<sup>2)</sup> The stud frame of the wall construction is to be supplemented with bars above and below each group in such a way that they form the reveal for the intended cable partition group

**Please do not put construction materials, such as mortar, inside the boxes.**

# COMBINATION FIRE PARTITION W

System  
C

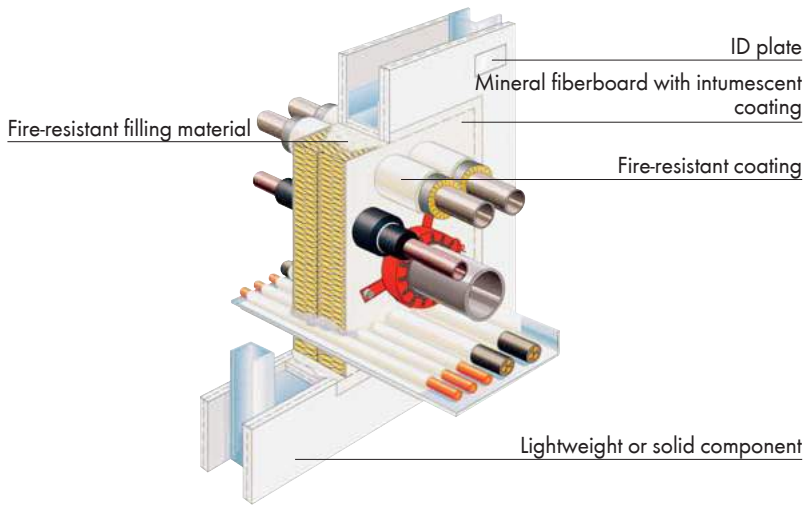

**Versatile partition system made of mineral fiberboard panels and an intumescent coating for cables and flammable and non-flammable pipes.**

**Processing only permitted by highly-trained specialized personnel!**

**Würth offers fire-protection seminars for users.**

## Required for new installation

- 63** = Fire-resistant coating
- 64** = Fire-resistant filling material
- 21** = Fire-resistant sleeve
- 42** = Pipe insulation
- 69** = Plus intumes. mat
- 41** = Mineral fiberboard

The products listed above can be found in the fire-protection products specifications.

## Required for retrofitting

See at left

## Test reports and approvals for the following applications

Wall and ceiling ducts S 90 Z-19.15-1413	Product Approval for fire-resistant coating Z-19.11-1389	Product Approval for fire-resistant filling material Z-19.11-1388
--	---	--

## Properties

Seals off fire and combustion gases, seals off rooms, resistant to splash water and aging, permanently elastic. Forms an insulating layer when exposed to heat.

## Areas of use

Both cables of all types and pipes of flammable and non-flammable materials may be routed through the partition.

## Notes

The cables, lines or pipes are encased on both sides for a length of 20 cm with 1-mm thick fireproof coating.

Applications	
Fire-resistance duration as per DIN 4102, Part 9	S 90
In walls and ceilings made of	concrete, masonry and light building materials with the fire-resistance rating $\geq$ F 90
For cables	of all types
Maximum filling	60% of the opening in the unfinished opening calculated for the cable cross-section

Dimensions		Pipe insulation	
<b>Dimensions</b>	<b>S 90</b>	<b>Option 1:</b>	
Solid wall thickness	$\geq 100$ mm	Steel, stainless-steel, cast iron and copper pipes insulate 1 x 40 mm thick over a length of 20 cm on both sides and coat with fireproof coating.	
Ceiling thickness	$\geq 150$ mm	<b>Option 2:</b>	
Light partition walls	$\geq 100$ mm	d (in mm)	l (in mm) per side
Maximum opening in unfinished opening - solid wall	1,200 mm (width) x 2,000 mm (height)		S
Maximum opening in unfinished opening - ceiling	1,500 mm x $\infty$	$\leq 50$	$\geq 500$
Maximum opening in unfinished opening - light partition walls	1,250 mm (width) x 1,700 mm (height)	$\leq 50-168.3$	$\geq 1,000$
		Copper	$\geq 1,000$
			40
			40
			40
<b>Partition thickness</b>	<b>S 90</b>		
Wall	$\geq 100$ mm		
Ceiling	$\geq 100$ mm		
Distance to next partition	$\geq 200$ mm		

**System**  
**C1**

# Fire Partition W1



**Partitioning system for electrical lines consisting of a mineral fibreboard provided with an intumescent coating on both sides.**

**Processing only permitted by highly-trained specialised personnel!**  
**Würth offers fire protection seminars for users.**

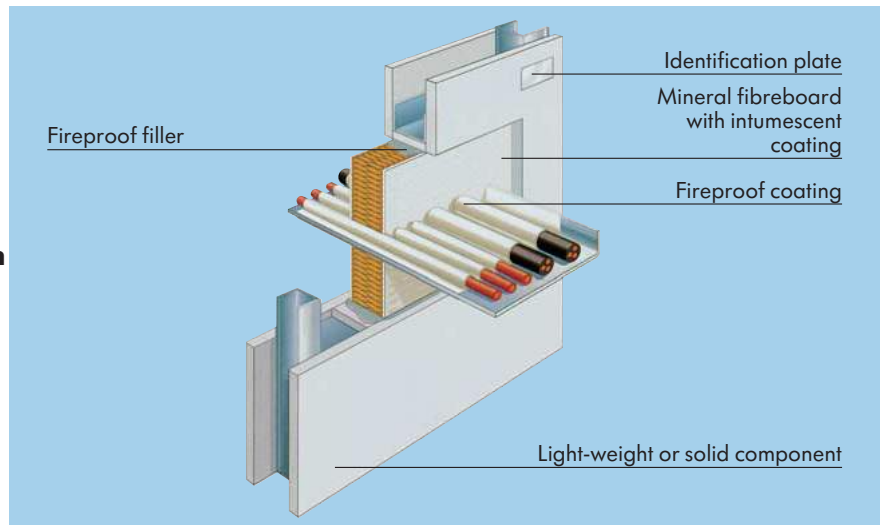

**The following are required for initial installation**

- 63** = Fireproof coating
- 64** = Fireproof filler
- 41** = Mineral fibreboard 80 mm

**The following are required for subsequent installation**

See list at left

The products listed above can be found in the fire protection products specifications.

**Test reports and approvals** for the following applications

Wall and ceiling ducts S 90 Z-19.15-1493	Product Approval for Fireproof coating Z-19.11-1389	Product Approval for Fireproof filler Z-19.11-1388
--	--	---

**Applications**

For sealing wall and ceiling ducts with a fire-resistance rating of S 90 pursuant to DIN 4102, Part 9 for cables, cable bundles and cable-support systems.

**Only one 80 mm thick plate required for S 90.**

**Properties**

Seals off fire and combustion gases, seals off rooms, resistant to splash water and aging, permanently elastic.  
Forms an insulating layer when exposed to heat.

**Notes**

The cables and cable bundles are encased on both sides for a length of 20 cm with 1 mm thick fireproof coating.

**Applications**

Fire endurance according to standard DIN 4102, Part 9	S 90
In walls and ceilings of	concrete, masonry and light partition walls with the fire-resistance rating $\geq$ F 90
For cables	of all types
Maximum filling	60% of the opening in the unfinished opening calculated for the cable cross-section

**Dimensions**

Dimensions	S 90
Wall thickness of concrete	$\geq$ 100 mm
Wall thickness of masonry	$\geq$ 115 mm
Ceiling thickness	$\geq$ 150 mm
Light partition walls	$\geq$ 100 mm
Maximum opening in unfinished opening - solid wall	1,200 mm (width) x 2,000 mm (height)
Maximum unfinished opening - light partition wall	800 mm (width) x 500 mm (height)
Ceilings	400 mm (width) x unlimited length

**Partition thickness**

Partition thickness	S 90
general	80 mm

# FIRE RESISTING FOAM 90

System  
D1

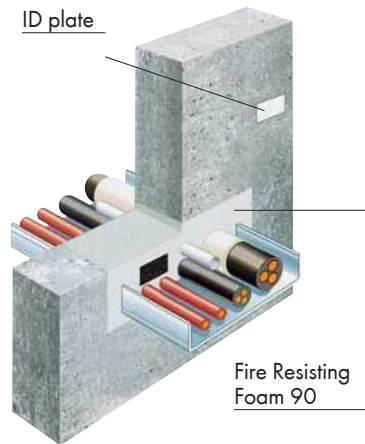
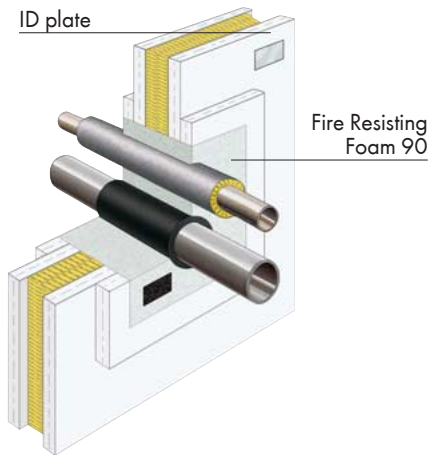

Simple sealing system for all types of cables, lines and pipes by means of fire-resistant foam.

### Required for new installation

- 35** = Fire-resistant foam 90 Molded parts BS2 / Valve gripper / Adapter
- 63** = Fireproof coating
- 68** = Intumescent strips
- 44** = FLEXEN® stone wool mats

The products listed above can be found in the fire-protection product specifications.

### Required for retrofitting

- 35** = Fire-resistant foam 90
- 63** = Fireproof Coating
- 68** = Intumescent strips
- 44** = FLEXEN® stone wool mats

### Test reports and approvals for the following applications

Wall and ceiling  
ducts  
S 90  
Z-19.15-1472

Wall and ceiling  
ducts  
R 90  
Z-19.17-1773

### Properties

- Seals off fire and combustion gases.
- Seals off rooms.
- Simple application
- Has sound-insulating effect and is easy to retrofit.

### Notes

Shake can thoroughly. The foam must have a processing temperature of at least 15°C. Cables with an outside diameter > 20 mm must be provided with fireproof coating over a length of 20 cm on both sides. Greatest possible cable diameter is 55 mm (S 90 according to Z-19.15-1472). Flammable and non-flammable pipes up to a maximum outside diameter of 159 mm may be routed through the partition (R 90 according to Z-19.17-1773). Details are contained in the respective approvals. The can can be used for up to 1 year, even when used several times.

Applications		
Fire resistance as per DIN 4102, Part 9	<b>S 90</b> according to Z-19.15-1472	<b>R 90</b> according to Z-19.17-1773
In walls and ceilings made of	solid components and light partition walls	solid components and light partition walls
For cables and optical waveguides	all types	-
For pipes	-	all types
Maximum filling	60% of the unfinished opening calculated for the cable/pipe cross-section	

Dimensions		
<b>Dimensions</b>	<b>S 90</b> according to Z-19.15-1472	<b>R 90</b> according to Z-19.17-1773
Wall thickness for masonry	≥ 100 mm	≥ 100 mm
Wall thickness for concrete	≥ 100 mm	≥ 100 mm
Wall thickness for light partition walls	≥ 100 mm	≥ 100 mm
Ceiling thickness	≥ 150 mm	≥ 150 mm
Maximum opening in carcass in walls	≤ 500 cm <sup>2</sup> , however not higher than 20 cm or wider than 50 cm	≤ 500 cm <sup>2</sup> , however not higher or wider than 50 cm, and dia. ≤ 25 cm than 20 cm
Maximum opening in carcass in ceilings	≤ 500 cm <sup>2</sup> , however not higher than 20 cm or wider than 50 cm	≤ 500 cm <sup>2</sup> , however not higher or wider than 50 cm, and dia. ≤ 25 cm than 20 cm

Partition thickness		
<b>Partition thickness</b>	<b>S 90</b> according to Z-19.15-1472	<b>R 90</b> according to Z-19.17-1773
Wall	≥ 150 mm	≥ 150 mm
Ceiling	≥ 150 mm	≥ 150 mm

**System**  
**D2**

# Intumescent Cable Partition



Simple partitioning system made of mineral wool and an intumescent fire-retardant filler for cables and electrical lines of all types.

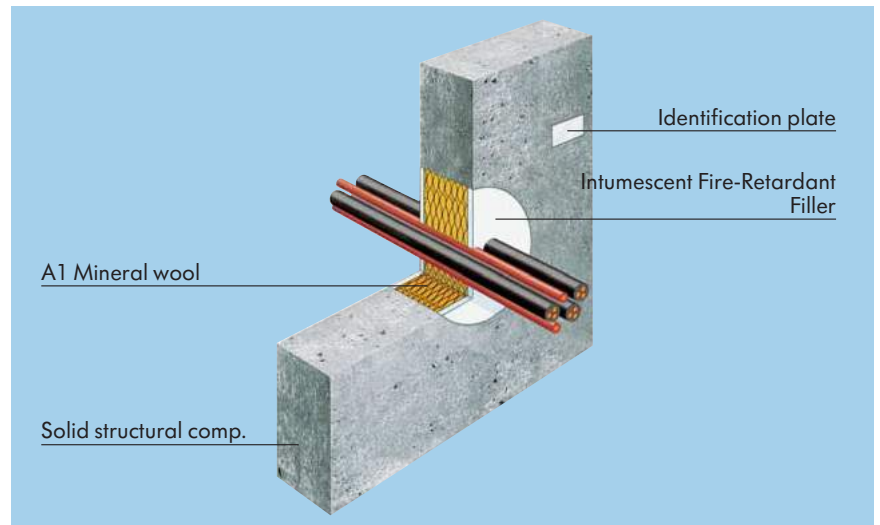

**The following are required for initial installation**

**The following are required for subsequent installation**

- 62** = Intumescent Fire-Retardant Filler
- 43** = Mineral wool

- 62** = Intumescent Fire-Retardant filler

The products listed above can be found in the fire protection products specifications.

**Test reports and approvals** for the following applications

Wall and ceiling ducts S 90 Z-19.15-1483	Product Approval for Fire-Retardant Filler Z-19.11-1116
--	--

**Applications**

For sealing wall and ceiling ducts with a fire-resistance rating of S 90 pursuant to DIN 4102, Part 9 for electrical cables and lines of all types.

**Properties**

Easy processing, especially suitable for irregular small-size openings or core-drilled holes. Forms an insulating layer when exposed to heat. Halogen- and silicone-free.

**Notes**

Plug up unfinished opening solidly with mineral wool and close off opening on both sides with at least 10 mm of Fire-Retardant Filler.

**Applications**

Fire endurance according to standard DIN 4102, Part 9	S 90
In walls and ceilings of	concrete and masonry with the fire-resistance rating $\geq$ F 90
For cables	of all types
Maximum filling	60% of the opening in the unfinished opening calculated for the cable cross-section

**Dimensions**

Dimensions	S 90
Wall thickness of concrete	$\geq$ 150 mm
Wall thickness of masonry	$\geq$ 150 mm
Ceiling thickness	$\geq$ 150 mm
Maximum opening in unfinished opening - wall/ceiling	max. 100 cm <sup>2</sup> (round or with corners)
Partition thickness	S 90
general	$\geq$ 150 mm

**System  
D3**



# Intumescent 2 Comp. Fire Resisting Foam

**Partition system for partitioning electrical cables and non-flammable pipes according to LAR, consisting of a two-component intumescent fire resisting foam.**

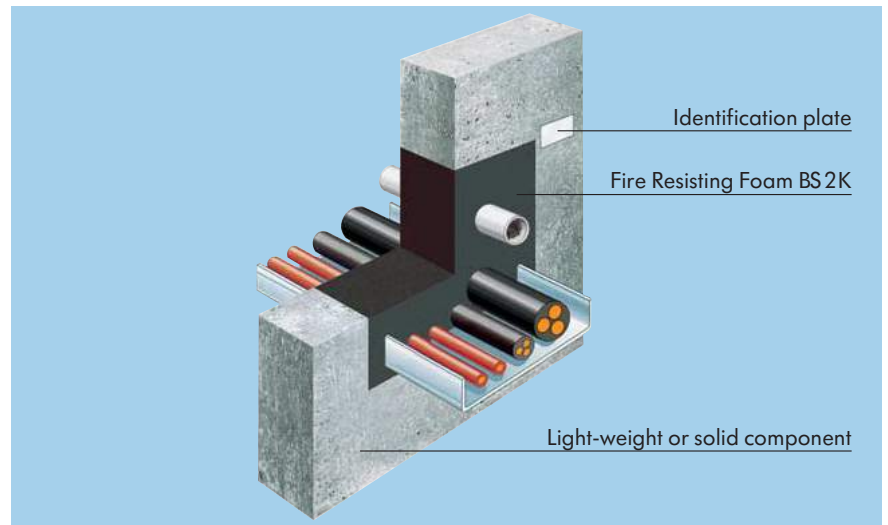

### Required for new installation

**36** = Fire resisting foam BS 2K/  
Application gun BS 2K 2:1

### Required for retrofitting

**36** = Fire resisting foam BS 2K/  
Application gun BS 2K 2:1

The products listed above can be found in the fire protection products specifications.

### Test reports and approvals for the following applications

Wall and ceiling ducts S 90 Z-19.15-1722	Product Approval for Fire Resisting Foam BS 2K Z-19.11-1717	Pipe partition R 90 AbP P-3167/6595-MPA BS
--	--	---

### Applications

Partitioning of electrical cables according to permit Z-19.15-1722.  
Partitioning of non-flammable pipes up to 88.9 mm dia. according to AbP P-3167/6595-MPA BS.  
Cable and pipe ducts according to expert opinion and LAR.

### Properties

When installing expanding fire resisting foam, foam yield at +20°C approx. 2.0 litres. Intumescent (foaming) in case of fire. Colour: brown.  
Application temperature: +15°C to +30°C, ideally +20°C to +25°C.  
Reaction time: approx. 10 seconds. Can be cut: after approx. 30 seconds.

### Notes

Individual empty plastic pipes up to 20 mm dia. may be guided through the partition; close off both ends 20 mm with fire resisting foam BS 2K.  
Cable support systems may also be routed through walls.  
When partitioning pipes, the general conditions according to AbP P-3167/6595-MPA BS or LAR must be observed.

### Applications

Fire resistance according to DIN 4102, Part 9	S 90
In walls and ceilings made of	concrete, masonry and light partition walls with the fire-resistance rating $\geq$ F 90
For cables	all types
Maximum filling with cables	60% of the carcass opening
Partitions of non-flammable pipes	R 90 according to AbP P-3167/6595-MPA BS and according to LAR 2005 up to 160 mm dia. Ring gap between pipe and core-drilled hole may be a maximum of 15 mm. Filling at least 40 mm deep to both sides. Distance 1 x dia. between pipes.

**The installation instructions and the construction permit of the system must be observed!**

### Dimensions

Dimensions	S 90
Wall thickness for masonry and concrete	$\geq$ 100 mm
Ceiling thickness	$\geq$ 150 mm
Light partition walls	$\geq$ 100 mm
Maximum carcass opening in wall/ceilings	200 mm x 200 mm or 200 mm dia.
Partition thickness	S 90
Wall	$\geq$ 150 mm
Ceiling	$\geq$ 150 mm (cable $\leq$ 18 mm dia.) $\geq$ 200 mm (cable $>$ 18 mm dia.)

**System E**

# Fire-Retardant Pads 90



**Variable sealing system of fire-retardant pads for all types of cables and lines.**

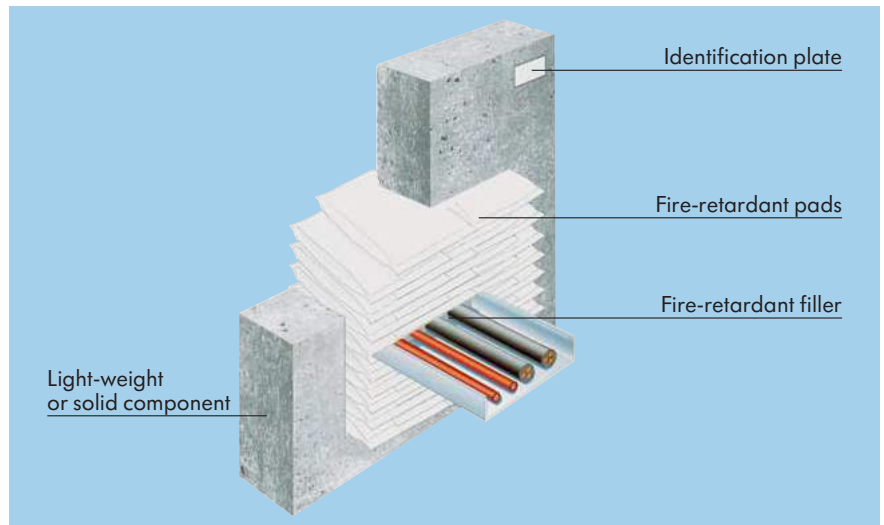

**The following are required for initial installation**

**The following are required for subsequent installation**

- 31** = Fire-retardant pads
- 62** = Fire-retardant filler

- 62** = Fire-retardant filler

The products listed above can be found in the fire protection products specifications.

**Test reports and approvals** for the following applications

Wall and ceiling ducts  
S 90  
Z-19.15-1117

**Properties**

- Seals off fire and combustion gases.
- Non-flammable.
- Seals off rooms.
- Easy installation.
- Can be reused after removal. Has sound-insulating effect and is easy to retrofit.
- Resistant to ageing, light-weight.

**Applications**

Mobile partition for dry construction work with the fire-resistance rating S 90 according to DIN 4102, Part 9 for cable ducts in solid ceilings and walls, as well as in light walls.

**Applications**

- For closing off wall and ceiling ducts for any type of electrical cables regardless of the respective cross-section, and for optical waveguides and cable support structures.
- For sealing off pneumatic lines and empty pipes of plastic for control purposes with a diameter ≤ 15 mm.
- Suitable for permanent sealing off or as a temporary partition during the construction phase.
- Later additions are possible and also checked at any time.
- Cable bundles and cables and lines installed at a later time must be sealed off with fire-retardant filler (Art. No. 0893 306).
- Installation permissible in both solid components and in light partition walls.
- Please observe the information and regulations of the installation instructions and the permit from the installation set.

**Applications**

Fire endurance according to standard DIN 4102, Part 9	S 90
In walls and ceilings of	solid components and in light partition walls
For cables and optical waveguides	of all types, regardless of respective cross-section
Maximum filling	60% of the opening in the carcass calculated for the cable cross-section

**Dimensions**

Dimensions	S 90
Wall thickness for masonry	≥ 100 mm
Wall thickness for concrete	≥ 100 mm
Ceiling thickness	≥ 150 mm
Light partition walls	≥ 100 mm
Maximum opening in carcass in walls	106 cm (width) x 150 cm (height)
Maximum opening in carcass in ceilings	60 cm (width); length not limited
Partition thickness	S 90
Wall	300 mm
Ceiling	300 mm

# FIRE PROTECTION STONES/PLUGS

System  
**E1**

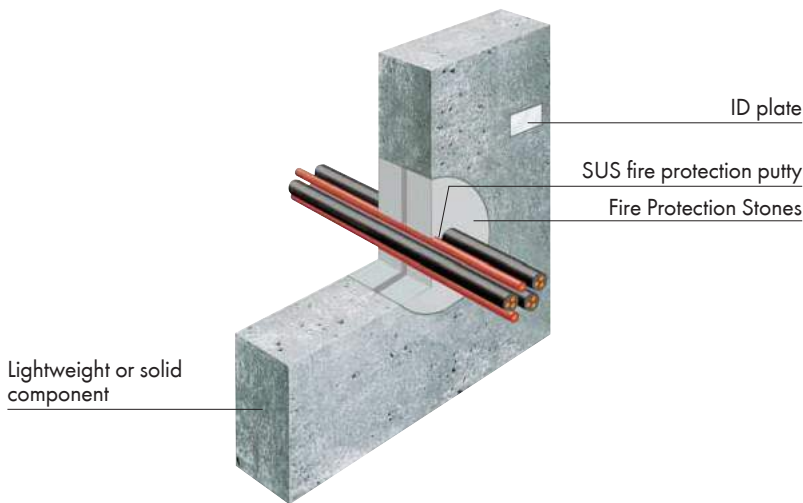

**Simple partition system comprised of ready-to-use molded parts, with an intumescent (foams in the event of a fire) effect. For partitioning individual cables or cable bundles. With the fire protection stones, the following can also be fed through: cable routes, copper pipes up to 28 mm or steel pipes up to 54 mm dia.**

## Required for new installation

- 32** = Fire protection stones or plugs
- 32** = SUS 1 fire protection putty

The products listed above can be found in the fire-protection product specifications.

## Required for retrofitting

- 32** = SUS 1 fire protection putty

## Test reports and permits for the following applications

Wall and ceiling ducts Fire protection plugs  
S 90  
Z-19.15-1495

Wall and ceiling ducts Fire protection stones  
S 90  
Z-19.15-1494

Product approval for fire protection putty SUS 1  
Z-19.11-1732

## Notes

The opening is to be closed off with fire protection stones or plugs and the cable gussets are to be filled up with the fire protection putty to the entire depth of the partition. For cable bundles  $\leq 100$  mm in diameter consisting of parallel-running, properly tied cables, the gussets do not need to be filled. Lead-through of non-flammable pipes and cable routes is only permissible with the fire protection stones. In the case of cable partitions, the wall or ceiling must be at least 20 cm thick and must be enhanced with surface stripping or construction of a frame if necessary.

## Properties

Easy processing, especially suitable for regular small- and medium-size openings or core-drilled holes.  
Forms an insulating layer when exposed to heat. Halogen- and solvent-free. Dust- and fiber-free.

Applications	
Fire-resistance duration as per DIN 4102, Part 9	<b>S 90</b>
In walls and ceilings made of	concrete, masonry and light partition walls with the fire-resistance rating $\geq$ F 90
For cables	all types
Maximum filling	60% of the opening in the unfinished opening calculated for the cable cross-section

Dimensions	
<b>Structural dimensions</b>	<b>S 90</b>
Wall thickness of concrete, masonry and light partition wall	$\geq 100$ mm
Ceiling thickness	$\geq 150$ mm
Max. unfinished opening in wall/ceiling with fire protection plugs	max. dia. 310 mm
Max. unfinished opening in wall with fire protection stones	1,000 mm (width) x 500 mm (height)
Max. unfinished opening in ceiling with fire protection stones	500 mm (width) x unlimited length

Partition thickness	
<b>S 90</b>	<b>S 90</b>
Fire Protection Plugs	$\geq 200$ mm to dia. 210 mm and $\geq 220$ mm to dia. 310 mm
Fire protection plugs, solid walls	$\geq 150$ mm to dia. 210 mm
Fire Protection Stones	$\geq 220$ mm
Distance to next partition	$\geq 50$ mm

# KB FIRE PROTECTION BANDAGE

System  
E3



**Cable bandage that foams up in the event of a fire, for preventing the fire from spreading via cables, cable bundles and cable conduits.**

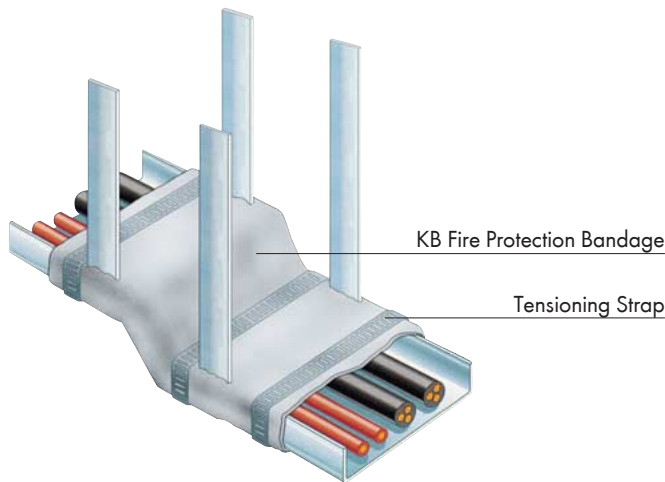

## Required for new installation

- 66** = KB fire protection bandage
- 66** = Universal Tensioning Strap
- 66** = Turnbuckle
- 66** = Winding wire

The products listed above can be found in the fire-protection product specifications.

## Required for retrofitting

See at left

## Test reports and permits for the following applications

System approval,  
fire protection bandage KB  
Z-56.217-3549

## Areas of use

Fire protection jacket for preventing fire from occurring and to prevent fire from spreading via cables and cable systems.

## Features

Snug-fitting installation or installation running along profile. No special suspension devices required. Short installation time. Simple installation even in hard-to-reach places. Easy retrofitting.

Dust-free installation.

## Applications

According to the new Regulations for Line Systems (LAR), now no fire load may be installed in required hallways so that all cables must be installed

in I 30 cable ducts or over F 30 intermediate ceilings. However, the problem often arises that this is no longer possible, as for example no space is available for additional suspension devices of the cable ducts or the hallway height would be restricted by an F 30 ceiling. The Würth KB fire protection bandage is used here to prevent the occurrence of fire and the spread of fire via cables and cable systems. The permissibility of use on cables and cable systems along rescue routes is to be decided upon in individual cases by the respective building supervisory board, e.g. in conjunction with the fire protection concept.

The KB fire protection fabric allows the cables, cable bundles and individual cables to be wrapped on non-flammable cable racks or ladders. In the same way, the occupied cable racks or ladders can also be completely wrapped. The KB fire protection fabric must be secured with tensioning straps or wire. In addition, a two-sided or three-sided covering of cables on solid components is also possible.

**Exact installation instructions are contained in the permit or the installation kit.**

## Installation options

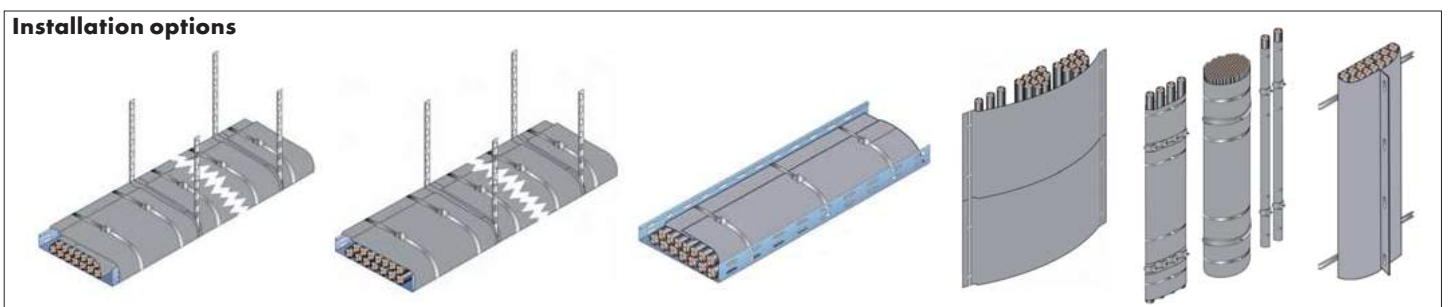

System  
**E 4**



# Fire- Protection Duct I 30/I 60/ I 90/I 120

I-duct for encapsulation  
of fire loads.

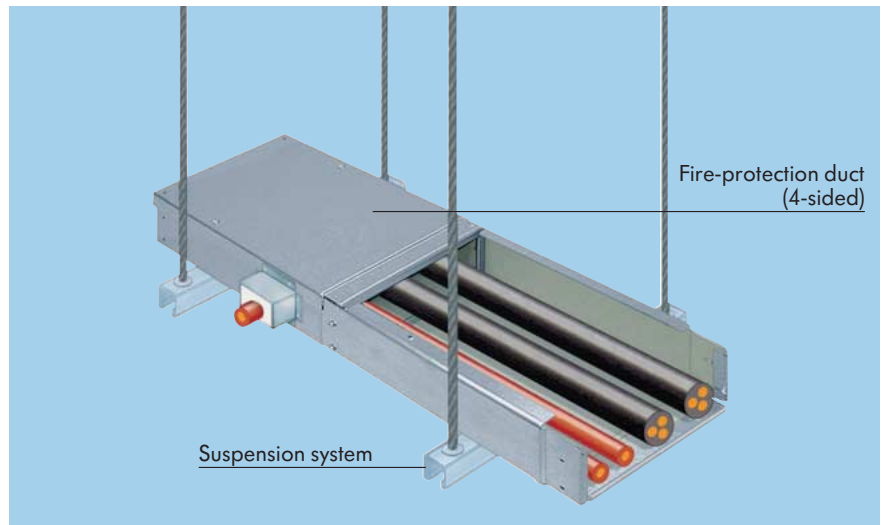

## Required for new installation

**65** = Fire-protection duct I 30/I 60/I 90/I 120

The products listed above can be found in the fire-protection products specifications.

## Test reports and approvals for the following applications

ABP  
General Construction  
Test Certificate  
P-MPA-E-09-011

## Applications

The fire-protection duct is for the fire-resistance ratings I30 to I120 in accordance with DIN 4102, Part 11. In escape and rescue routes and in required hallways and staircases. The fire-protection duct can be designed both as a 1-sided, 2-sided, 3-sided, 4-sided and as a round system.

## Properties/Information

- Consists of galvanized sheet metal with an insulating layer generator on the inner side.
- Not only protects the surrounding area like conventional I-ducts, also prevents fire from being passed on in the duct with its insulating layer generator.
- Simple, dust-free mounting.
- Low intrinsic weight.
- Reduces installation time by up to 80%.
- Maintenance-friendly.
- Constricted and difficult geometries also possible.
- Colored surface coating possible.
- Simple later additions.
- Also available in stainless steel.
- Suitable for cables, flammable pipes and non-flammable pipes with flammable synthetic rubber insulation.
- The fire-protection duct must be installed while exactly observing the installation instructions and Test Certificate No. P-MPA-E-09-011.

## Applications

**Comments of LAR on Section 3:** Line systems in rescue routes always represent an increased risk of fire, especially if flammable lines are concerned. However, the actual risk level is also dependent on the importance of the rescue route

- stairway as primary rescue route and
- required hallway as secondary rescue route

as well as on the arrangement of the line system itself. A distribution box represents a singular source of fire, which does not result in the fire being passed on, while a **cable conduit presents a** higher risk as a fuse. Fire protection measures listed in Section 3 must be evaluated under these aspects.

## Installation options

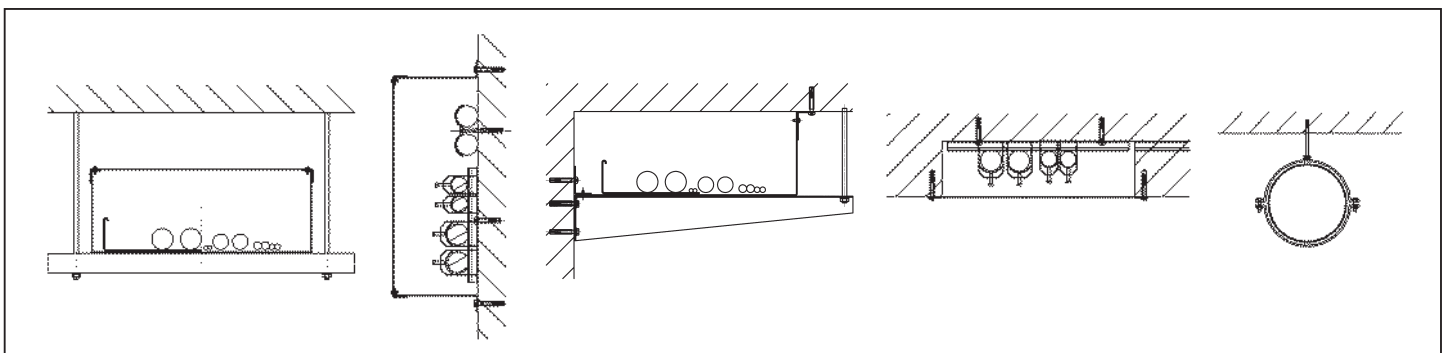

# PIPE PARTITION M

System  
F

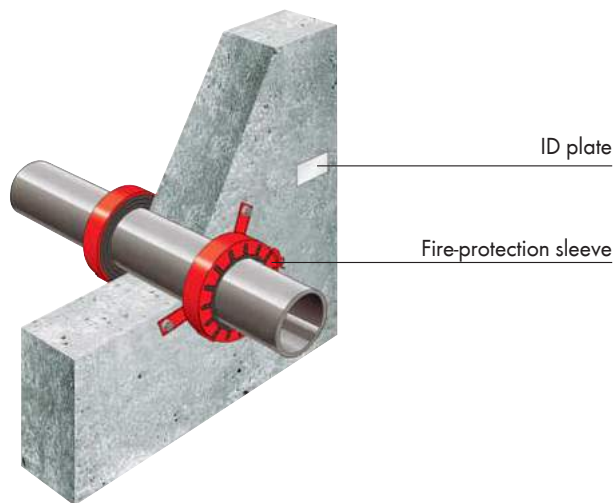

**Wall and ceiling partition system for insulated and non-insulated plastic pipes with pipe sleeve type RK I/ RK I plus.**

## Required for new installation

**21** = Type RK I/RK I plus Fire-Protection Sleeve

**11** = Fire-Retardant Cement MG III

The products listed above can be found in the fire-protection products specifications.

## Test reports and approvals for the following applications

R 90 Wall and Ceiling  
Ducts  
Z.19.17-1374

## Features

- Can be installed in extremely tight spaces.
- Suitable for retrofitting.
- Does not carry sound when installed properly.
- No loose fastening parts.
- Fastened with approved anchors (W-ZS Quick-Action Anchor) or directly in the mortar bed by bending the retaining brackets.
- Synthetic-rubber insulation can be routed through.
- 4 mm PE noise protection hose can be routed through.
- Resistant to high humidity.
- Control cables for pneumatic post systems may be routed through.
- Absolutely maintenance-free.
- The sleeve may be selected up to three sizes larger.
- Sleeve spacing of 0 mm possible, see permit.

## Notes

- The appropriate fire-protection sleeve is selected in accordance with the outside diameter of the plastic pipe to be protected.
- One sleeve is required for ceiling ducts, and two for wall partitions.
- The fire-protection sleeves are to be installed under precise observance of

## Areas of use

For wall and ceiling ducts of fire-resistance class R90 as per DIN 4102, Part 11, for plastic pipes of material class B1 and B2.

the installation instructions and permit (see Installation Set, Art. No. 0893 304 11).

- The plastic pipe must be closed off with non-flammable materials, e.g. System G or H, in the area of the wall or ceiling without hollow spaces. With certain pipe materials, a joint gap of 5 mm is permissible (see permit).
- Beverage hoses can also be sealed off.

## Applications

Pipe partition system for plastic pipes up to an outside diameter of 315 mm and pipe wall thicknesses of 1.8 to 18.4 mm.

Exact specifications are contained in construction permit Z-19.17-1374. The system can be used for water or waste-water pipes, pipelines with a conduit, pneumatic post and vacuum cleaner lines and noise decoupling waste-water pipes such as Raupiano from Rehau, Skolan DB from Ostendorf, Friaphon from Friatec, Geberit DB 20 from Geberit, Wavin AS and Wavin HT-PE from Wavin and PP pipe from Uponor. PE- or PP-based plastic composite pipe with up to 1 mm aluminum insert. Beverage hose up to max. 108 mm with sleeve pipe and electrical cable. PVDF pipes in accordance with ISO 10931 or permit No. Z-40.23-224.

## Installation options

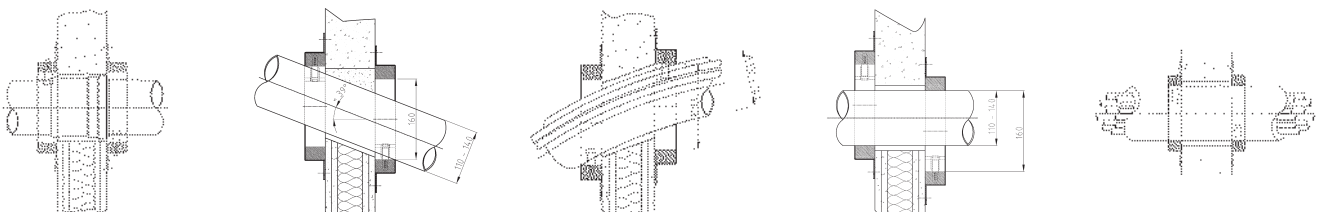

# PIPE PARTITION M

System  
F2



Lightweight

Wall and ceiling partition system for plastic pipelines.

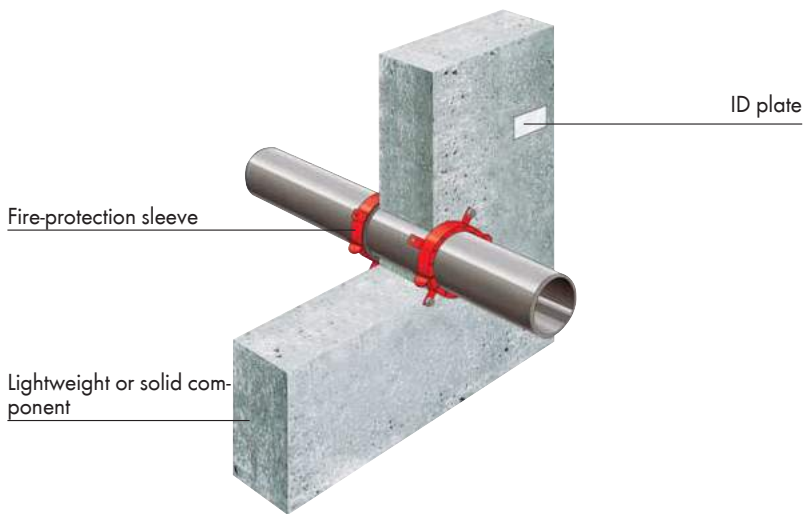

### Required for new installation

**22** = Fire-Protection Sleeve Type RK II

**11** = Fire-Retardant Cement MG III

The products listed above can be found in the fire-protection product specifications.

### Test reports and approvals for the following applications

Wall and ceiling ducts  
R90  
Z.19.17-1679

#### Properties

- Can be installed in extremely tight spaces.

- Suitable for retrofitting.
- Does not carry sound when installed properly.
- No loose fastening parts.
- Fastening with approved anchors (W-DN Ceiling Nails/W-ZS Quick-Action Anchors) or directly in the mortar bed by bending the retaining brackets.
- For straight and angled ducts.
- Bushings may lie in the sleeve area up to 110 mm.
- Can be used indoors and outdoors.
- Resistant to high humidity.
- Absolutely maintenance-free.
- Sleeve spacing of 0 mm possible, see permit.
- For special solutions, such as heat/cold-insulated pipes or beverage hoses, please use our sleeve type RK I.
- The foaming fire-protection strip does not contain any hazardous substances as per 76/769/EEC.

### Areas of use

For wall and ceiling ducts in solid components of fire-resistance class R 90 as per DIN 4102, Part 11, for plastic pipes of material class B1 and B2.

### Notes

- The appropriate fire-protection sleeve is selected in accordance with the outside diameter of the plastic pipe to be protected.
- The plastic pipe must be closed off with concrete or mortar of mortar group MG III, e.g. System H, in the area of the wall or ceiling, without leaving any hollow spaces.

### Applications

- For pipes made of PVC-U; PVC-HI, PVC-C, PP, PE-HD, LDPE, PB, ABS, ASA, PE-X, styrene copolymers.
- Raupiano pipes Plus, Skolan DB, Friaphon, Wavin AS, Wavin SiTech, Geberit DB 20, Polokal NG and Polokal 3-S.
- The system can be used with pipeline systems for non-flammable liquids or gases, for pneumatic post and dust extraction lines and for flammable gases as per DVGW Worksheet G 600.
- Precise data and specifications can be found in the approval and installation instructions at [www.wuerth.de/brandschutz](http://www.wuerth.de/brandschutz).

Dimensions	R 90
Solid wall thickness/Lightweight partition wall thickness	≥ 100 mm
Ceiling thickness	≥ 150 mm

### Installation options

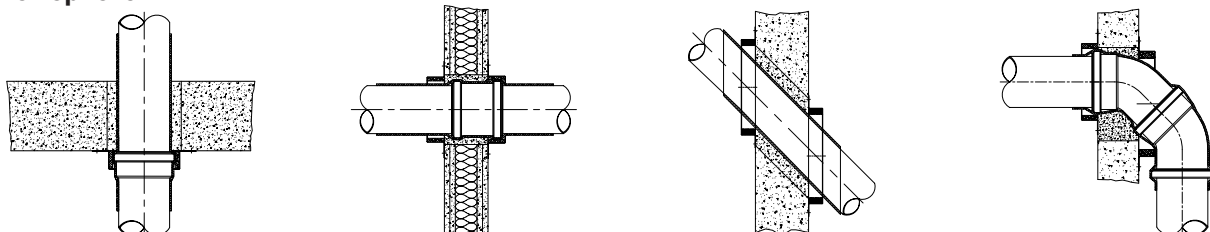

## I PLUS/I ISO PIPE PARTITION

System  
**F3**



inside

**Wall and ceiling partition system for insulated and non-insulated plastic pipes.**

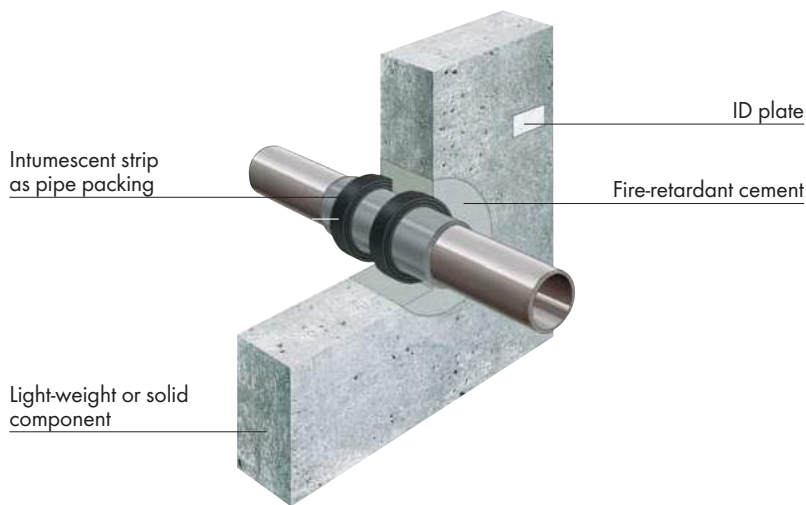

### Required for new installation

- 23** = Intumescent strip as pipe packing
- 11** = Fire-retardant cement MG III
- 62** = Fireproof filler

### Required for retrofitting

- 23** = Intumescent strip as pipe packing
- 11** = Fire-retardant cement MG III
- 62** = Fireproof filler

The products listed above can be found in the fire-protection products specifications.

### Test reports and approvals for the following applications

Wall and ceiling ducts  
R 90  
Z-19.17-1673

Wall and ceiling ducts  
R 90  
Z-19.17-1922

### Properties

- Absolutely maintenance-free. Can be installed in extremely tight spaces. No drilling or anchoring required.
- Extremely elastic material.
- Highly flexible for various pipe diameters.
- Adjacent packings may be installed for walls with distance of 0 mm.
- Water-resistant material.
- Self-adhesive.

### Applications

- For partitioning plastic pipes in F 90 solid walls and ceilings, and for light partition walls.

- For flammable pipes of the building material classes B1 and B2, I plus: with outside pipe diameter up to 160 mm for walls and 200 mm for ceilings/ I iso: with outside pipe diameter up to 110 mm in ceilings and walls.
- For pipes of PVC-U, PVC-HI, PVC-C and PP.
- For pipes of PE-HD, LDPE, PP, ABS, ASA, PE-X, PB and styrene copolymers.
- Sound-insulated drain pipes such as Rehau Raupiano; Skolan; Friaphon; Wavin AS; Wavin Si Tech; Polokal NG; Geberit DB 20.
- For pipes of mineral-reinforced plastics in accordance with general construction permits.
- For walls, two windings are required, however for ceilings only one winding on underside is required.
- I plus: Sound decoupling possible with 5 mm PE hose or with a layer of intumescent strips to the depth of the component.
- I iso: Duct of synthetic rubber insulation 6 to 32 mm and plastic composite pipe PE with up to 1 mm aluminum insert possible.
- Possible for gas lines as per DVGW Worksheet G 600.
- For precise specifications, please refer to the general construction permit I plus Z-19.17-1673/I iso Z-19.17-1922.

Applications	
Dimensions	R 90
Wall thickness for concrete	≥ 100 mm/or 150 mm
Wall thickness for masonry	≥ 100 mm/or 150 mm
Light partition wall	≥ 100 mm
Ceiling thickness	≥ 150 mm/or 200 mm

### Installation options

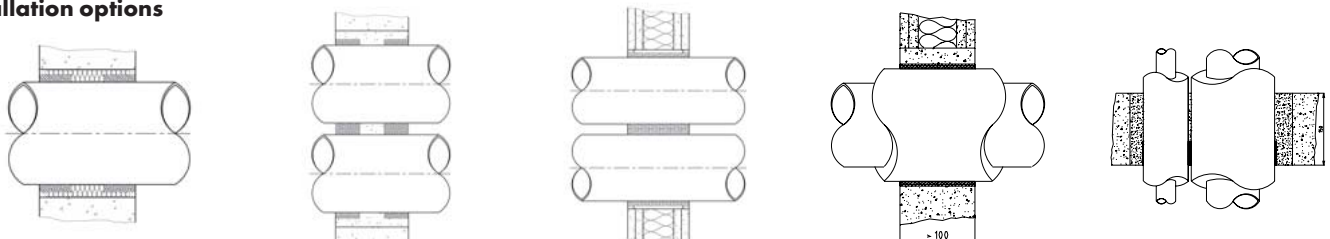

# System **G** Pipe Partition **E**



**Partition system for non-flammable pipes consisting of mineral wool A1 and a fire-protection silicone.**

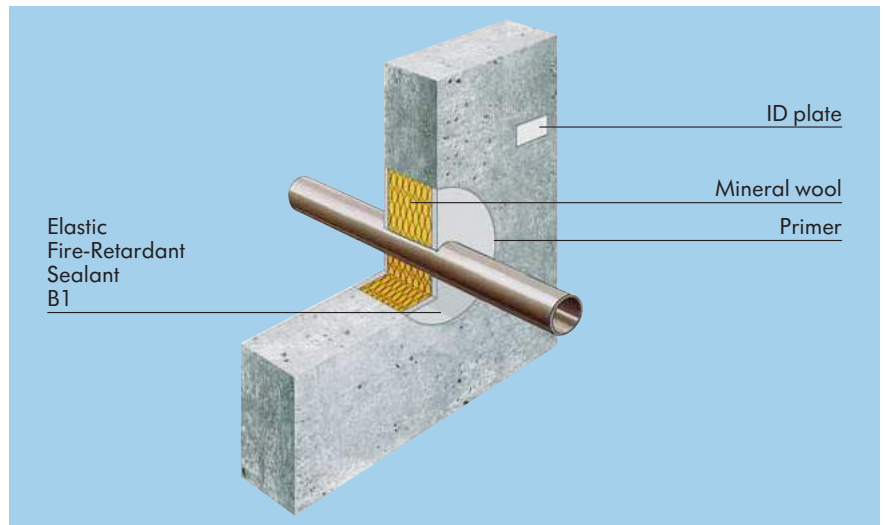

## Required for new installation

**43** = Mineral wool A1

**51** = Elastic fire-protection seal B1

if necessary **51** = silicone primer

The products listed above can be found in the fire-protection product specifications.

## Test reports and approvals for the following applications

System approval not required, as requirements are fulfilled as per LAR.

Product approval for elastic fire-protection seal B1  
P-MPA-E-00-583

## Applications

Pipe partition system for water and waste-water pipes. Can be used for pipe-in-pipe systems and pipes in core-drilled holes.

## Features

Gas-, water- and smoke-tight, pressure-resistant, can be moved even in case of fire. Sound decoupling of pipes from solid component.

Movement absorption

radial:  $\pm 10\%$  of the original joint width.

axial: 20% of the original joint width.

## Particularly important

The pipe partition system is especially suitable for sealing off thermally and mechanically moved pipes.

The mineral wool must be brought up to a nominal raw weight of  $90 \text{ kg/m}^3$ .

## Partition dimensions

The core-drilled hole may be max. 10 cm in dia. larger than the media pipe as per LAR.

## Fire-resistance duration

Closure as per LAR in F 90 components.

## Dimensions

Joint width	10 mm	20 mm	30 mm	40 mm	50 mm
Silicone installation depth	15 mm	15 mm	15 mm	15 mm	15 mm
Wall thickness	$\geq 100 \text{ mm}$	$\geq 100 \text{ mm}$	$\geq 100 \text{ mm}$	$\geq 100 \text{ mm}$	$\geq 100 \text{ mm}$

**System**  
**G1**

# Pipe Partition intumescent



**Partition system for non-flammable pipes up to 160 mm outside diameter and for flammable pipes up to 32 mm outside diameter, consisting of a material that swells in the event of a fire. F 90 in accordance with DIN 4102 and LAR.**

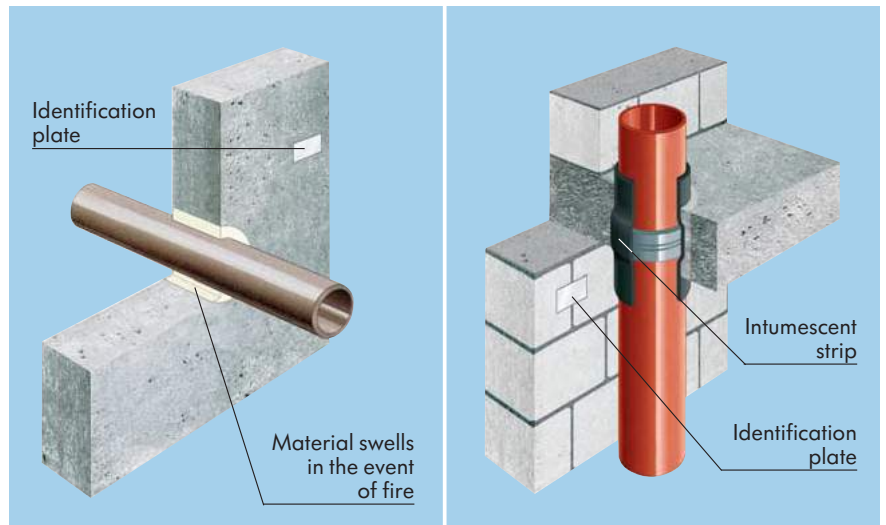

## Required for new installation

- |                                     |               |
|-------------------------------------|---------------|
| <b>62</b> = Fireproof filler        | for Variant 2 |
| <b>68</b> = Intumescent strips      | for Variant 3 |
| <b>11</b> = Fireproof cement MG III | for Variant 3 |

The products listed above can be found in the fire protection products specifications.

## Test reports and approvals for the following applications

System: F 90 in accordance with LAR, when the all-round joint gap between the core drilling and the pipe is not greater than 15 mm, or the intumescent strip is used.	Product approval: Fireproof filler Z-19.11-1116	Product approval, Intumescent strip Z-19.11-1438	Technical report noise protection measurement
--	---	--	---

## Applications

Pipelines with an outside diameter up to 160 mm made of non-flammable materials, also with coatings made of flammable materials up to 2 mm thick and for flammable pipelines up to 32 mm outside diameter.

## Properties

### Possible application 2:

For core drilling, the cavity between the core drilling and the media pipe is filled with a material that swells in the event of a fire (e.g. with fireproof filler or with an intumescent fireproof seal). This all-round joint gap may be max. 15 mm wide. These 15 mm can be regarded as a mean value (10 mm and 20 mm also possible). In the case of walls/ceilings of >80 mm, the intumescent material only needs to be installed to a depth of 40 mm on both sides. Stuff with rock wool on the inside.

If non-flammable insulation is laid around the pipe, the joining gap between the insulation and the core drilling must not be greater than 15 mm and is filled with the aforementioned materials.

### Possible application 3:

Stick one layer of self-adhesive intumescent strips around the pipe. The rest of the opening is sealed with cement mortar or concrete to eliminate cavities.

## Dimensions

The minimum thickness of the wall or ceiling must be 80 mm. All-round joint gap max. 15 mm (for Variant 2).

**The spacing of the individual lines are specified in the current Regulation for Line Systems (LAR).**

## Fire resistance duration

In accordance with LAR in F 90 components.

**System  
G2**

# Pipe Partition dB

**Intumescent**



**Ceiling partition system for non-flammable pipelines**

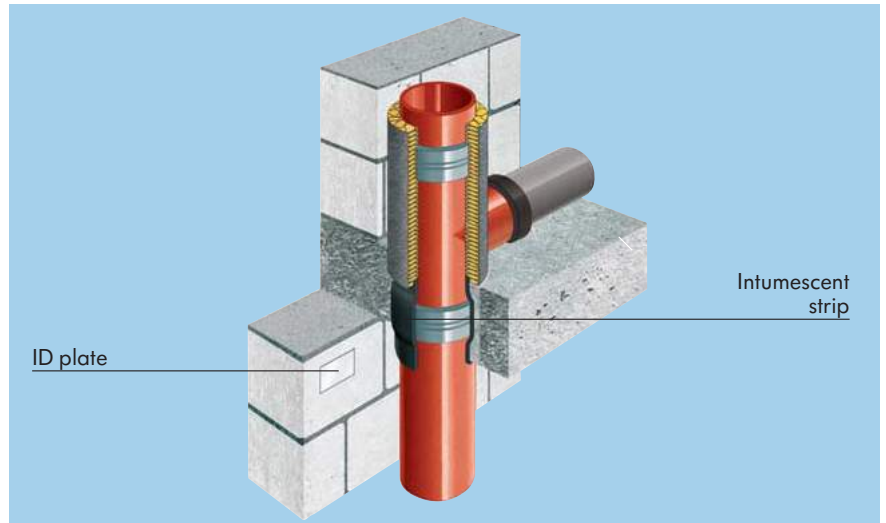

## Required for new installation

**68.1** = intumescent strip dB

**44** = flexen® stone wool mats

**11** = fire-retardant cement (gap closure)

**12** = fire-retardant mortar (gap closure)

The products listed above can be found in the fire-protection products specifications.

## Test reports and approvals for the following applications

Ceiling ducts  
R30 / R60 / R90  
P-3375/440/09-MPA BS

Sound test report  
P-BA 18/2009

## Applications

- R30 / R60 / R90 partition for non-flammable pipes (SML cast metal pipes) up to dia. 125 mm.
- In solid ceilings made of concrete and aerated concrete that are  $\geq 150$  mm.
- Also suitable for buildings with stricter sound protection requirements pursuant to VDI Guideline 4100.

## Properties

- Zero-spacing of the stone wool mats is possible.
- Easy to install.
- Transition from cast metal pipes to plastic pipes directly after the ceiling is possible.
- Intumescent strip dB is self-adhesive.
- Seals off fire and smoke.
- No set SML connector position.

## Dimensions

Fire-resistance rating	R30 / R60 / R90	
Concrete and reinforced concrete ceiling thickness	$\geq 150$ mm	
Aerated concrete ceiling thickness	$\geq 150$ mm	
	Insulation length	Insulation thickness
Cast metal $\leq$ DN 50	$\geq 100$ mm	$\geq 1 \times 30$ mm
Cast metal $\leq$ DN 125	$\geq 300$ mm	$\geq 1 \times 30$ mm

The installation instructions and construction test certificate must be followed!

## Installation options

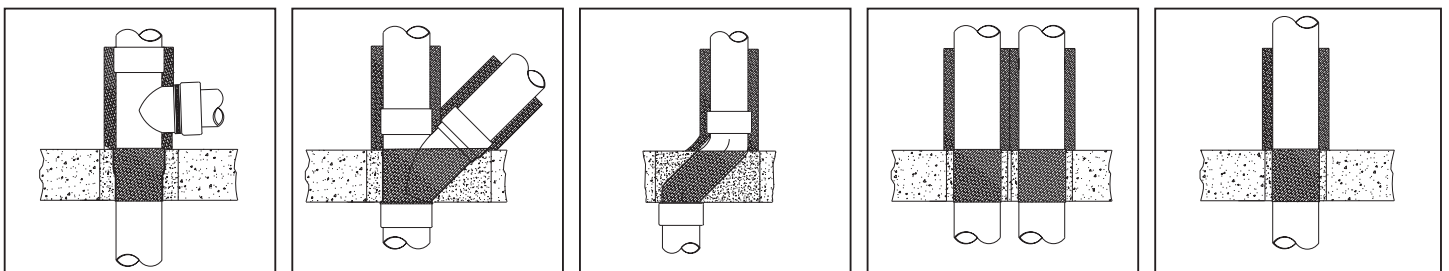

# PIPE PARTITION Z

System  
H

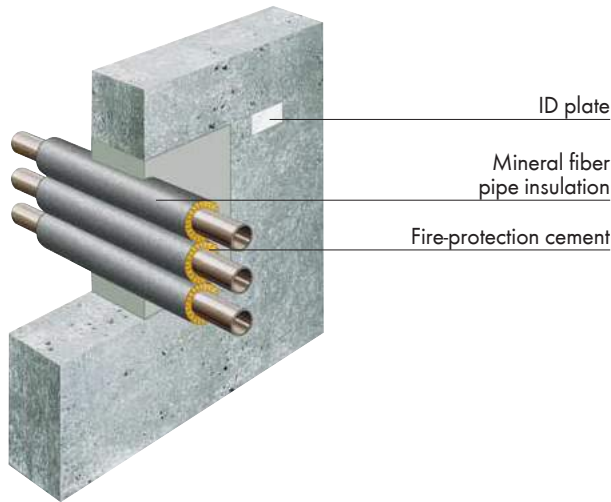

ID plate

Mineral fiber  
pipe insulation

Fire-protection cement

**Partition system of special mortar for wall and ceiling ducts of non-flammable pipes.**

### Required for new installation

- 11** = Fire-retardant cement
- 42** = FLEXEN® pipe insulation

The products listed above can be found in the fire-protection product specifications.

### Required for retrofitting

- 12** = Fireproof mortar (alternative)
- 44** = FLEXEN® stone wool mats

### Test reports and approvals for the following applications

Wall and ceiling  
ducts R 90  
in solid components  
P-3933/2404 -  
MPA BS

Fireproof cement  
MPA Hannover  
101609.1-TH

Pipe insulation  
A2  
melting point  
≥ 1000°C

### Areas of use

Pipe partition of fire-protection cement or fire-protection mortar for water or waste-water pipes.

For sound decoupling and for the absorption of longitudinal expansion, the pipes are provided with pipe insulation of material class A, melting point ≥ 1000°C.

The pipe insulation must have a nominal raw density of at least 40 kg/m<sup>3</sup>.

For non-flammable and flammable gases and liquids, pneumatic post lines and vacuum cleaner lines.

### Features

Seals off fire and combustion gases, reduces temperature, seals off rooms, resistant to splash water and water jets (fire fighting), mechanically stable.

### Permissible filling

Non-flammable pipes ≤ 159 mm dia. with a distance from insulation to insulation of 0 mm possible.

### Fire-resistance duration

R 90 in acc. with DIN 4102, Part 11.

Dimensions		
Pipe insulation		
Steel, stainless steel, cast iron	Thickness in mm	Insulation length in mm
≤ 16	1 x 30	600
> 16 ≤ 54	1 x 30	700
> 54 ≤ 114.3	1 x 40	1,000
> 114.3 ≤ 159	2 x 30	1,000
Copper pipes		
≤ 16	1 x 30	600
≤ 54	1 x 30	1,000
≤ 88.9	2 x 30	1,400

**System**  
**H1**

# KL Pipe Partition



**Partition system using special mortar of the mortar group III for wall and ceiling openings for non-combustible cold piping.**

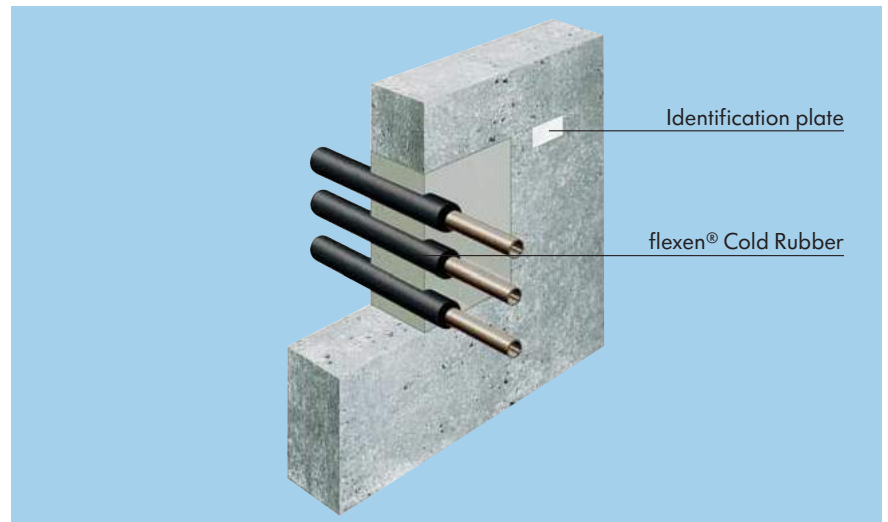

## Required for new installation

**11** = Fire-Retardant Cement MG III

**48** = flexen® Cold Rubber

The products listed above can be found in the fire-protection products specifications.

## Test reports and approvals for the following applications

<p>Fire-Retardant Cement mortar of the mortar group III Text Certificate issued by the MPA (materials testing office) Hanover</p>	<p>System: Pipe Partition flexen® K ISO Partition R 30 to R 120 P-MPA-E-01-037</p>
---	--

## Applications

Pipe ducts for cold piping through fire walls.

Non-combustible pipes for cold piping which are isolated using flexen® cold rubber can be routed through fire walls despite the fact that the material belongs to building material class B1 if the conditions stipulated in the test certificate P-MPA-E-01-037 are fulfilled.

## Properties

Steel, stainless steel or cast-metal pipes up to an outer diameter of 114 mm with a maximum insulation thickness of 32 mm can be routed through pipe partitions in F 90 walls and ceilings to ensure fire-resistance class R 90.

If copper pipes are used, the maximum outer diameter of the pipe is 54 mm with a maximum insulation thickness of 32 mm.

## Partition dimensions

The size of the opening is not limited.

A stretch of mortar of at least 50 mm is required between the insulations.

## Fire-resistance time

F 30 to F 120 according to pipe diameter and insulation thickness.

# PIPE PARTITION

System  
H2



## Intumescent mat plus

**Partition system for partitioning off non-flammable pipes in cold piping and flammable insulation by means of an intumescent mat.**

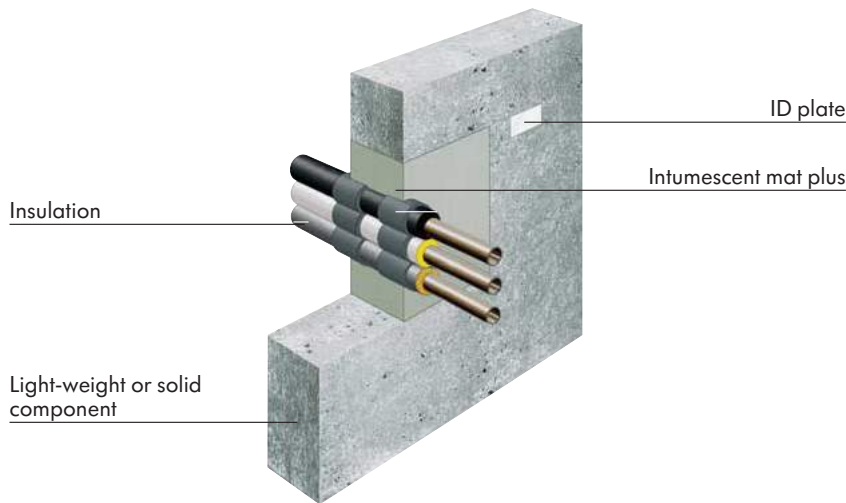

### Required for new installation

- 69** = Intumescent mat plus
- 48** = FLEXEN® Cold Rubber
- 11** = Fire-retardant cement MG III

The products listed above can be found in the fire-protection products specifications.

### Required for retrofitting

See at left

### Test reports and approvals for the following applications

Wall and ceiling ducts  
R 90 in solid components  
P-3680/8053-MPA BS

Wall ducts R 30 - R 90  
for light partition walls  
P-3682/8073-MPA BS

Product approval,  
intumescent mat plus  
Z-19.11-1569

### Features/Information

Easy to install, because only 1.1 mm thick. Can also be retrofitted. Foams up in the event of fire. For **synthetic rubber, polyurethane and mineral fiber** of at least material class B2 and for **foamed glass** of

### Areas of use

For wall and ceiling ducts of fire-resistance rating R 30 to R 90 in accordance with DIN 4102 in solid components and light partition walls for partitioning off cold piping in restricted spaces and for all flammable insulation.

at least material class A in accordance with DIN 4102. **Distance from insulation to insulation 0 mm.** For steel, stainless steel, cast iron and copper pipes.

Areas of application	
Fire endurance according to standard DIN 4102, Part 11	R 30 – R 90
In walls and ceilings made of	Concrete, masonry and light partition walls with fire-resistance rating $\geq$ F 90
For pipes made of	steel, stainless steel, cast iron and copper
Wrapping	at least 2 layers (also single-layer in the case of mineral fiber and foamed glass)

Dimensions	
Dimensions	R 90
Wall thickness, concrete or masonry	$\geq$ 150 mm / or from dia. 326 mm $\geq$ 200 mm
Ceiling thickness	$\geq$ 150 mm
Wall thickness, light partition walls	For F 30 $\geq$ 75 mm for F 90 $\geq$ 100 mm
Maximum pipe diameter steel, stainless steel, cast iron	$\leq$ 326.0 mm    Insulation thickness 6-100 mm
Maximum pipe diameter steel, stainless steel, cast iron	$\leq$ 813.0 mm    Insulation thickness 25-100 mm
For light partition walls for steel and cast iron pipes	$\leq$ 219.1 mm    Insulation thickness 9-100 mm
For light partition walls for stainless steel pipes	$\leq$ 204.0 mm    Insulation thickness 9-100 mm
Maximum pipe diameter for copper	$\leq$ 88.9 mm    Insulation thickness 9-100 mm

It is essential to refer to the general construction test certificates for the materials, pipe outside diameters, pipe wall thicknesses and insulation thicknesses.

# PIPE PARTITION

System  
**H3**



## Intumescent Strip plus

Partition system for enclosing non-flammable pipes with flammable and non-flammable insulation with an intumescent strip.

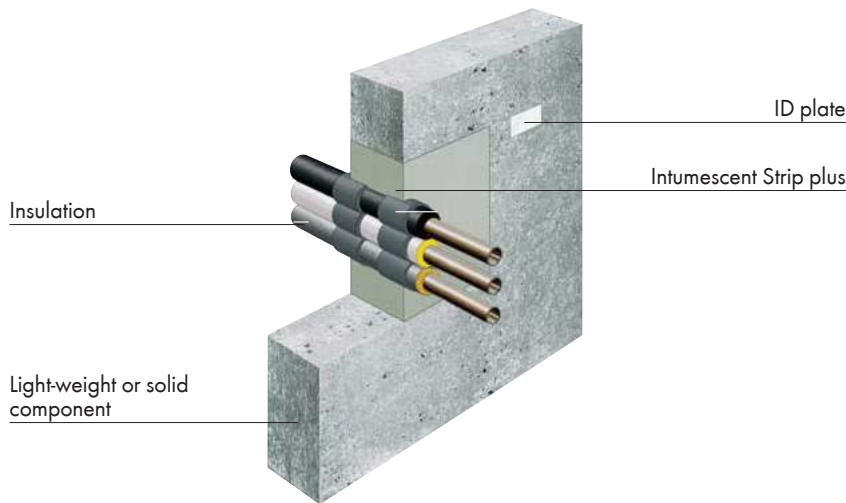

### Required for new installation

- 67** = Intumescent Strip plus
- 48** = FLEXEN® Cold Rubber
- 11** = Fire-retardant cement MG III

The products listed above can be found in the fire-protection products specifications.

### Required for retrofitting

See at left

### Test reports and approvals for the following applications

Wall and ceiling ducts  
R 90 in solid components and wall ducts  
R 30 - R 90 in light partition walls  
P-3333/2736-MPA BS

### Areas of use

For wall and ceiling ducts of fire-resistance rating R 30 to R 90 in accordance with DIN 4102-11 in solid components and light partition walls for partitioning off cold piping in restricted spaces and for all flammable insulation.

### Features/Information

Easy to install, because only 1.5 mm thick. Foams up in the event of fire. For synthetic rubber and polyurethane, at least material class B2, and for foamed glass and mineral fibers, at least material class A pursuant to

DIN 4102. **Spacing of the wound insulation may be 0 mm.** For steel, stainless steel, cast iron and copper pipes.

Areas of application	
Fire endurance according to standard DIN 4102, Part 11	R 30 - R 90
In walls and ceilings made of	Concrete, masonry and light partition walls with fire-resistance rating $\geq$ F 90
For pipes made of	steel, stainless steel, cast iron and copper
Wrapping	at least one layer

Dimensions		
Fire-resistance rating	R 90	R 30
Wall thickness, concrete or masonry	$\geq$ 150 mm	-
Concrete ceiling thickness	$\geq$ 150 mm	-
Wall thickness, light partition walls	$\geq$ 100 mm	$\geq$ 75 mm

Material	Maximum pipe diameter	
	Solid walls and ceilings	Light partition walls
Steel and cast iron	$\leq$ 326.0 mm	$\leq$ 204.0 mm
Stainless steel	$\leq$ 204.0 mm	$\leq$ 204.0 mm
Copper	$\leq$ 88.9 mm	$\leq$ 88.9 mm

It is essential to refer to the general construction test certificates for the materials, pipe outside diameters, pipe wall thicknesses and insulation thicknesses.

**System**  
**I**

# Joint System K



**Partition system of special mortar for ceiling and wall ducts of fire protection flaps.**

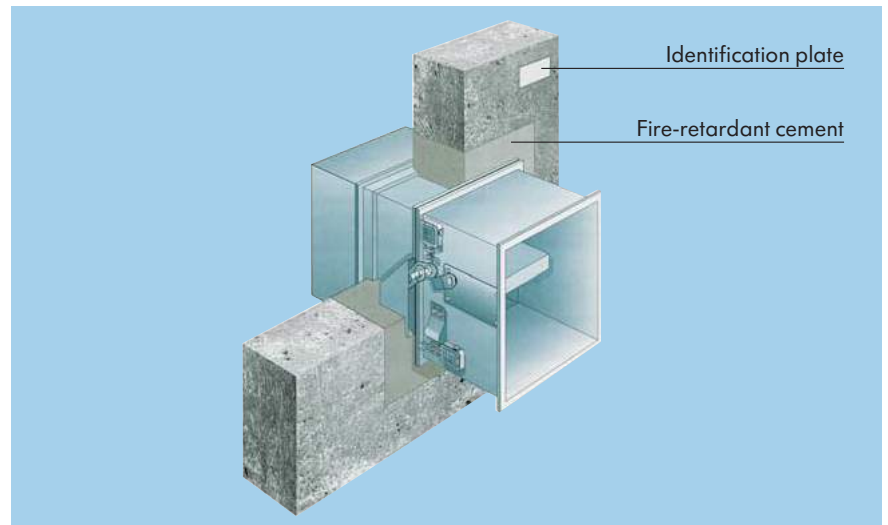

## Required for new installation

**11** = Fire-retardant cement MG III

The products listed above can be found in the fire protection products specifications.

## Test reports and approvals for the following applications

The permit of the respective fire-protection flap manufacturer must be observed.	Fire-retardant cement Mortar of Mortar Group III Test Certificate of MPA Hanover
--	--

## Applications

Partition system of fire-retardant cement for ceiling and wall ducts of fire-protection flaps in solid walls and ceilings.

## Properties

Easy to install due to excellent pumping properties when filling with the pressing method. Seals off fire and combustion gases, reduces temperature, seals off rooms, resistant to water jets (fire fighting), mechanically stable.

## Permissible filling

As desired; freely selectable ventilation cross-sections.

## Partition dimensions

In accordance with requirements of the permits of fire protection flaps.  
The surrounding joint gap should be at least 6 cm (see permit of flap manufacturers).

## Fire resistance duration

F 30 – F 120 according to DIN 4102.

**System**  
**J**

# Joint System **E**



**Heavy-duty joint sealing system of non-flammable mineral wool and fire-retardant silicone.**

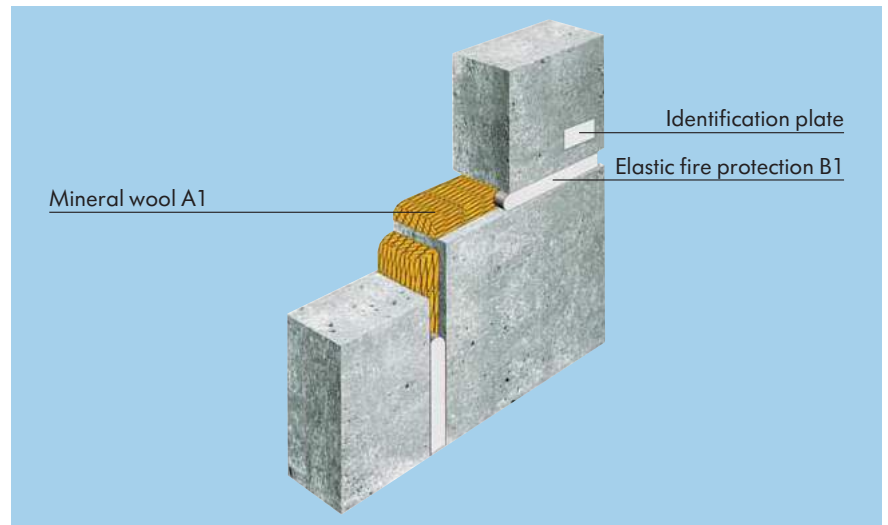

### Required for new installation

- 43** = Mineral wool A1
- 51** = Elastic fire-retardant sealant B1
- 51** = Pre-coating for silicone

The products listed above can be found in the fire protection products specifications.

### Test reports and approvals for the following applications



### Applications

Expansion and separating joints in walls and ceilings.

### Properties

Seals off fire and smoke, reduces temperature, seals off rooms, permanently elastic, resistant to water, elastic even at low temperatures, provides intensive acoustic and thermal insulation.

### Notes

- The joint formation should be based on DIN 18540 and DIN 18545.
- Surfaces must be dry, clean and grease-free.
- Smoothing must be carried out with a neutral smoothing agent, such as the Sealant Smoothing Agent for Silicone (Art. No. 0893 3).

### Fire resistance duration

F 90 according to DIN 4102.

### Dimensions

Joint width	10 mm	20 mm	30 mm
Silicone installation depth	15 mm	15 mm	15 mm
Wall thickness	≥ 100 mm	≥ 100 mm	≥ 100 mm

## JOINT SYSTEM P

System  
L



**Highly elastic joint sealing system made of fireproof impregnated polyurethane foam.**

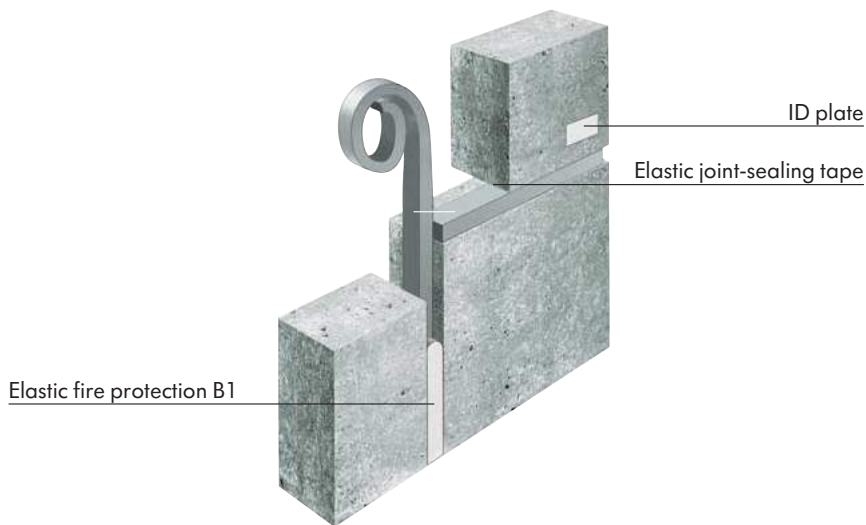

### Required for new installation

**81** = Elastic joint-sealing tape

**51** = Optional, elastic fireproof seal B1

The products listed above can be found in the fire-protection products specifications.

### Test reports and approvals for the following applications

Test certificate for the system:  
P-3568/2560 MPA BS

Material test certificate:  
P-ift-261 2 8579

### Applications

Expansion and separating joints in walls, ceilings and wall connections.

### Features

Seals off fire and smoke, seals off rooms, permanently elastic even at low temperatures, provides intensive acoustic and thermal insulation. Compatible with silicone and acrylate sealing compounds. The joint-sealing tape contains no silicone.

### Notes

- The joint formation should be based on DIN 18540 and DIN 18545.
- Sub-surfaces must be dry, clean and grease-free.
- Smoothing must be carried out with a neutral smoothing agent, such as the Sealant Smoothing Agent for Silicone (Art. No. 0893 3).

### Fire-resistance duration

F 30 – F 120 as per DIN 4102 (depending on fire-resistance duration of components and installation depth).

### Dimensions

Maximum joint width: 45 mm.

# 11 Fire-Retardant Cement MG III



Mortar belonging to mortar group III in accordance with DIN 1053-1 classified as building material A1 in accordance with DIN 4102-4

Bucket	15 kg
Sack	25 kg
Application set	



## General construction permit / test reports

Fire-retardant cement  
Mortar belonging to mortar group III  
Test Certificate from MPA (materials testing office), Hanover

### 1. Application

- For use in system **B1** + **F** + **F2** + **F3** + **G1** + **G2** + **H** + **H1** + **H2** + **H3** + **I**
  - Cable box **B1**
  - M Pipe partition **F**
    - M Pipe partition lightweight **F2**
  - I Pipe partition plus / iso **F3**
  - Intumescent pipe partition **G1**
  - Intumescent pipe partition dB **G2**
  - Z Pipe partition **H**
    - KL Pipe partition **H1**
  - Pipe partition intumescent mat plus **H2**
  - Pipe partition intumescent strips plus **H3**
  - Joint system K **I**
- Sealing wall and ceiling ducts for insulated and non-insulated, non-inflammable pipes.
- Can also be used to seal partitions with several ducts since

there is no limit to pipe diameter or partition dimensions.

- Sealing wall and ceiling ducts for insulated and non-insulated, non-inflammable plastic pipes with a diameter of < 32 mm with no further measures.
- To insulate wall and ceiling ducts, please always use mineral wool A1 or A2 in accordance with DIN 4102, melting point < 1000°C.

### 2. Advantages

Also stable at considerable build-up heights.

### 3. Properties

- Seals off fire and combustion gases, reduces temperature, seals off rooms, resistant to splash water and water jets (fire fighting), mechanically stable.
- Suitable for pumping, pressing or for manual application.
- Ready-to-use mixture.

### Procedure for use



Clean opening and moisten reveal.



Premix dry cement. First put water, then cement into the mixing container. Mix for 4 minutes at 300 to 400 rpm.



Apply fire-retardant cement. Board up larger ducts on one side.



Apply ID plate.

### Dimensions

- No limit to partition dimensions
- Non-inflammable pipes ≤ 150 mm without fire-protection sleeve
- Inflammable pipes < 32 mm

### Yield

- With 15 kg of dry mortar, 9 l of moist mortar can be made by adding 3 l of water.
- With 25 kg of dry mortar, 15 l of moist mortar can be made by adding 5 l of water.

### Calculation of requirements

<b>Example:</b>	Partition	L x B (length by width)	40 x 40 cm
	Fire-protection hatch	l · b (length by width) approx.	20 x 20 cm
	Partition thickness	T	approx. 20 cm
F1	Partition	(40 · 40 cm)	= 1,600 cm <sup>2</sup>
- F2	Fire-protection hatch	(20 · 20 cm)	= 400 cm <sup>2</sup>
F	Surface area to be sealed		= 1,200 cm <sup>2</sup>
	Partition thickness T (20 cm) x surface area to be sealed F (1,200 cm <sup>2</sup> )		= 24,000 cm <sup>3</sup>
	1 kg dry mortar		≙ 560 cm <sup>3</sup>
	560 cm <sup>3</sup>	= 1 kg mortar	
	24,000 cm <sup>3</sup>	= X	
	$X = \frac{24,000 \times 1}{560}$	= <b>42 kg</b> dry mortar	

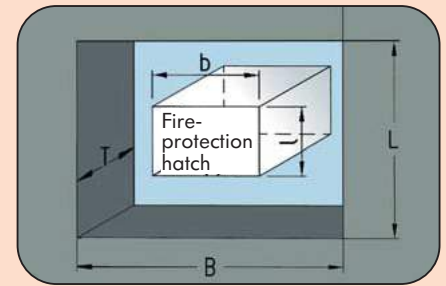

<b>Calculation form:</b>	Partition	L x B (length by width)	..... cm
	Fire-protection hatch	l · b (length by width)	approx. .... cm
	Partition thickness	T	approx. .... cm
F1	Partition	= L (..... cm) x B (..... cm)	= ..... cm <sup>2</sup>
- F2	Fire-protection hatch	= l (..... cm) x b (..... cm)	= ..... cm <sup>2</sup>
F	Surface area to be sealed		= ..... cm <sup>2</sup>
	Partition thickness T (..... cm) x surface area to be sealed F (..... cm <sup>2</sup> )		= ..... cm <sup>3</sup>
	1 kg dry mortar		= ..... cm <sup>3</sup>
	560 cm <sup>3</sup>	= 1 kg mortar	
	..... cm <sup>3</sup>	= X	
	$X = \frac{..... \times 1}{560}$	= ..... <b>kg</b> dry mortar	

### Ordering information

Designation	Packaging	Contents	Art. No.	P. Qty.
<b>Fire-Retardant Cement MG III</b>	Bucket	15 kg	<b>0893 307 15</b>	1
	Sack	25 kg	<b>0893 307 25</b>	42
<b>Application set</b>	poly bag	2 ID plates, test certificate and notes on application	<b>0893 307 2</b>	1

# FIRE-RETARDANT MORTAR

12



Bucket 10 kg

Sack 20 kg

Mounting kit

## General construction permit / test reports

Wall and ceiling  
ducts  
S120  
Z-19.15-812

Wall and ceiling  
openings  
S90  
Z-19.15-1333

### 1. Area of use

- For working in the system **M** + **W** + **G2** + **H**
  - Combination partition **M**
  - Fire partition **M** **W**
  - Pipe partition dB **G2**
  - Pipe partition Z **H**
- Closing wall and ceiling ducts of fire-resistance duration S 90 and S 120 in accordance with DIN 4102, Part 9, for cables, cable bundles and cable-carrying systems, and for combination partitions.
- For medium-sized to large ducts with the possibility of post-assignment when using wedges for subsequent installation.

### 2. Advantages

- High yield.
- Good stability – therefore less formwork complexity.
- Very good adhesion to base surface on steel, concrete and masonry.

### 3. Properties

- Seals off fire and combustion gases, reduces temperature, seals off rooms, resistant to splash water and water jets (firefighting).
- Does not cause corrosion to steel braces in reinforced concrete.
- Neutral reaction to PVC cables.
- Suitable for pumping or for manual application.
- Resistant to aging.
- Chemically neutral.
- Free of toxic substances that can damage the skin and the environment.

### Note on processing



Clean the opening and pre-wet the reveal of the structure.



Premix dry mortar. Put water followed by mortar into the mixing container. Mix for 3 minutes at 300-400 rpm.



Installing the fireproof mortar: Shutter larger ducts on one side.



Installation of wedges for subsequent installation for later installation.



Affix the ID plate.



For subsequent installation: Remove the wedges for subsequent installation with gentle hammer strikes.

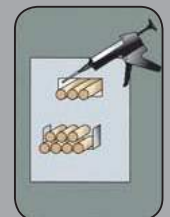

Subsequent installation of cables: Re-seal the remaining opening.

# FIRE-RETARDANT MORTAR

12

Dimensions		
The following dimensions must be maintained for the application of fireproof mortar:		
	Wall partition	Ceiling partition
<b>Minimum thickness of structural component</b>	see System description System A and B	see System description System A and B
<b>Max. partition size:</b> Width height / length		
<b>Minimum work space from cable route to upper reveal of the structure</b>		
<b>Distance between cable conduits</b> (horizontal)		
<b>Minimum distance between cable conduits</b> (vertical)		
<b>Minimum distance to next partition</b>		

Technical Data			
<b>Raw material base</b>	Cement and mineral aggregates	<b>Application temperature</b>	≥ 5°
<b>Shelf life</b>	at least 1 year	<b>Bending tensile capability</b>	approx. 0.8 – .5 N/mm <sup>2</sup>
<b>Mixing ratio</b>	10 kg: 3 litres	<b>Application time</b>	Approx. 60 minutes
<b>Unfinished density</b>	approx. 1.05 kg ± 0.1 dm <sup>3</sup>	<b>Compressive strength</b>	approx. 2.5 – 5.0 N/mm <sup>2</sup>

Yield
<ul style="list-style-type: none"> <li>• Add about 6 litres of water to the contents of a 20 kg sack or about 3 litres to contents of a 10 kg bucket.</li> <li>• 20 kg of dry mortar produce approx. 20 l of wet mortar.</li> <li>• <b>Shelf life:</b> At least 1 year if kept in a cool dry place.</li> </ul>

Need assessment			
<b>Example:</b>	Cable partition	L x W	25 x 30 cm
	Cable assignment	l · w	approx. 10 x 7 cm
	Partition thickness	T	approx. 20 cm
F1	Cable partition = L (25) cm * W (30) cm	=	750 cm <sup>2</sup>
- F2	Cable assignment = l (10 cm) * w (7 cm)	- =	70 cm <sup>2</sup>
F	Surface area to be sealed	=	680 cm <sup>2</sup>
	Partition thickness T (20) * surface area to be sealed F (680)	=	13,600 cm <sup>3</sup>
	1 kg dry mortar	≙	1,000 cm <sup>3</sup>
	1,000 cm <sup>3</sup>	=	1 kg mortar
	13,600 cm <sup>3</sup>	=	X
	$X = \frac{13,600 \times 1}{1,000}$	=	13.6 kg
<b>Calculation basis:</b>	Cable partition	L x W	..... cm
	Cable assignment	l · b	approx. .... cm
	Partition thickness	D	approx. .... cm
F1	Cable partition = L (25) cm * W (30) cm	=	..... cm <sup>2</sup>
- F2	Cable assignment = l (10 cm) * w (7 cm)-	=	..... cm <sup>2</sup>
F	Surface area to be sealed	=	..... cm <sup>2</sup>
	Partition thickness T (.....) * surface area to be sealed F (.....)	=	..... cm <sup>3</sup>
	1 kg dry mortar	=	1000 cm <sup>3</sup>
	1,000 cm <sup>3</sup>	=	1 kg mortar
	..... cm <sup>3</sup>	=	X
	$X = \frac{..... \times 1}{1,000}$	=	..... kg

Ordering data				
Designation	Packaging	Contents	Art. No.	P. Qty.
Fire-Retardant Mortar	Bucket	10 kg	0893 302	1
	Sack	20 kg	0893 302 20	12/24
Mounting kit	Poly bag	2 ID plates, approval and installation instructions	0893 302 1	1

## PIPE SLEEVE, TYPE RK I / TYPE RK I PLUS

21



Fire-protection sleeve

Mounting Kit

Fastening material

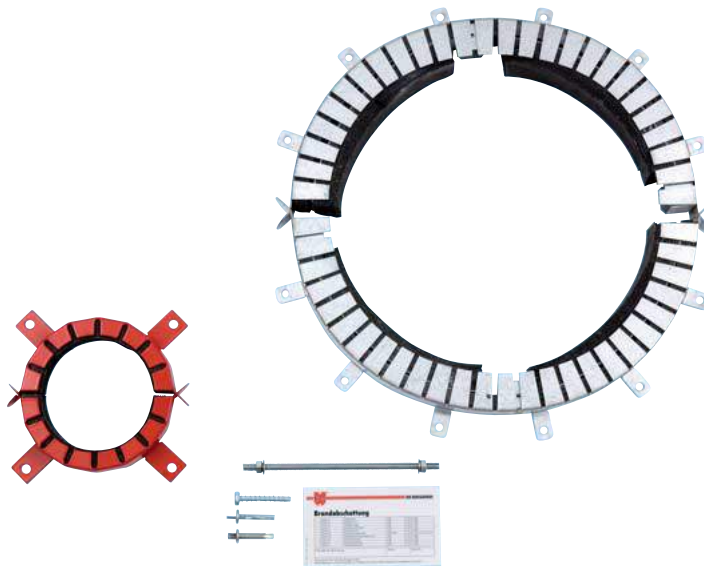

### General Construction Permit/Test Reports

Wall and Ceiling Ducts  
R 90  
Z-19.17-1374

#### 1. Application

- For use in system + +
  - Combination partition
  - Fire partition W combination
  - Fire-protection sleeve
- For wall and ceiling ducts
- Fire-resistance rating R90 in accordance with DIN 4102, Part 11.
- For flammable pipes of material classes B1 and B2 with outside diameter up to 315 mm.
- For multi-layer composite pipes and pipe systems with protective pipe (double pipe system).
- For pneumatic post systems and vacuum cleaner lines.
- For masonry and concrete walls and ceilings, also for light partition walls.
- For F90 walls from 100 mm: 1 Sleeve on each side of the wall.
- For F90 ceilings from 150 mm: 1 Sleeve on the ceiling underside.
- Beverage hoses can also be sealed off as per the approval.

#### 2. Advantages

- Suitable for retrofitting.
- Synthetic rubber-insulated pipes (insulation  $\leq 43$  mm) up to dia. 250 mm can be routed through the sleeve.
- Space-saving installation thanks to low sleeve height.
- Can be installed in extremely tight spaces.
- No loose fastening parts.
- No preassembly.
- Few attachment points.
- Additional sound protection possible.
- Can also be used at high temperatures.
- Moisture does not impair the function.
- Control cables for pneumatic post systems may be routed through.
- Solid foam withstands the pressure of firefighting water.
- The spacing between sleeves can be 0 mm.

#### 3. Properties

- Absolutely maintenance-free.
- Extremely simple handling
- Can be reused after removal.

#### 4. Notes

- Select the correct sleeve for the outside diameter of the pipe being protected.
- In difficult installation situations, a sleeve up to three sizes larger can also be selected (applies up to a pipe outside diameter of 110 mm).
- Up to a sleeve diameter of 200mm, the sleeve can be mortared in without using an anchor by bending the retaining brackets.

#### Notes on application

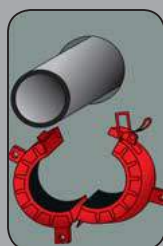

Close the remaining gap between the plastic pipe and the reveal. Place the folded-over sleeve around the plastic pipe.

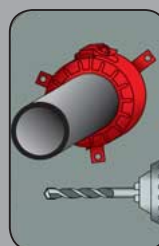

Close the sleeve. Secure the sleeve with an anchor or mortar in the bent-over brackets.

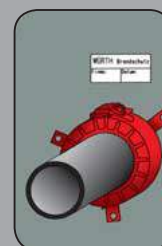

Affix the ID plate.

## PE SLEEVE TYPE RK I / TYPE RK I PLUS

21

<b>Dimensions</b>					
<b>The following dimensions are required for application of fire protection sleeve:</b>					
Plastic pipe outside diameter from 32 to 315 mm.					
Sleeve diameter mm	≤ 200	> 200 - ≤ 280	> 280 - ≤ 315	≤ 280	> 280 - ≤ 315
Minimum thickness of structural component	Wall Partition R 90			Ceiling Partition R 90	
Masonry in accordance with DIN 1053-1	100 mm	150 mm	200 mm	-	-
Concrete, reinforced concrete in acc. with DIN 1045	100 mm	150 mm	200 mm	150 mm	200 mm
Light partition walls in accordance with DIN 4102	100 mm	-	-	-	-

<b>Ordering information</b>						
Designation		Ø mm inside	Ø mm outside	Height in mm	Art. No.	P.Qty.
<b>Pipe Sleeve Type RK I*</b>	32	36	50	26,0	<b>0893 304 033</b>	2/40
	50	54	68	26,0	<b>0893 304 050</b>	2/40
	63	67	94	26,0	<b>0893 304 063</b>	2/14
	75	79	106	26,0	<b>0893 304 075</b>	2/32
	90	94	132	26,0	<b>0893 304 090</b>	2
	110	114	155	26,6	<b>0893 304 110</b>	2
	125	129	172	40,0	<b>0893 304 125</b>	2
	140	144	200	40,0	<b>0893 304 140</b>	2
	160	164	220	40,0	<b>0893 304 160</b>	2
	180	184	264	40,0	<b>0893 304 180</b>	2
	200	204	284	40,0	<b>0893 304 200</b>	2
	225	231	311	60,0	<b>0893 304 225</b>	1
	250	256	336	60,0	<b>0893 304 250</b>	1
<b>Pipe Sleeve Type RK I plus</b>	280	289	378	51,0	<b>0893 304 280</b>	1
	300	314	403	51,0	<b>0893 304 300</b>	1
	315	328	417	51,0	<b>0893 304 315</b>	1
<b>Application Set</b>	(Permit, installation instructions, 2 ID Plates)				<b>0893 304 11</b>	1
<b>Ceiling Anchor W-ZS</b>	for mounting				<b>0905 365 005</b>	200
<b>Ceiling Nail W-SA</b>	for mounting				<b>0901 160 030</b>	200
<b>Threaded Rod</b>	for mounting				<b>0958 6</b>	1

The information is taken from the current permit and are nominal dimensions without information on production tolerances.

\* Other sizes available on request.

## PIPE SLEEVE TYPE RK I / TYPE RK I PLUS

21

Possible uses for the sleeve with oblique or curved ducts without synthetic rubber insulation:

Designation		Sleeves Inside dia. in mm	Media pipe dia. from - to in mm	Art.-No.
Pipe Sleeve Type RK I*	32	34	0 - 32	<b>0893 304 033</b>
	50	54	25 - 50	<b>0893 304 050</b>
	63	65	32 - 63	<b>0893 304 063</b>
	75	77	40 - 74	<b>0893 304 075</b>
	90	94	50 - 90	<b>0893 304 090</b>
	110	112	63 - 110	<b>0893 304 110</b>
	125	127	75 - 125	<b>0893 304 125</b>
	140	144	90 - 140	<b>0893 304 140</b>
	160	162	110 - 160	<b>0893 304 160</b>
	180	182	161 - 180	<b>0893 304 180</b>
	200	202	181 - 200	<b>0893 304 200</b>
	225	231	201 - 225	<b>0893 304 225</b>
	250	256	226 - 250	<b>0893 304 250</b>
Pipe Sleeve Type RK I plus	225	239	201 - 225	<b>on request „S“</b>
	250	264	226 - 250	<b>on request „S“</b>
	280	289	251 - 280	<b>0893 304 280</b>
	300	314	281 - 300	<b>0893 304 300</b>
	315	328	301 - 315	<b>0893 304 315</b>

Approval extension up to dia. 315 mm already granted.

\*Other sizes possible on request.

## PIPE COLLAR TYPE RK II

22



Fire-protection sleeve

Mounting kit

Fastening material



### General construction permit/test reports

Wall and ceiling ducts R 90 in solid components Z-19.17-1679

#### 1. Area of use

- For use in the system **F2**
- For F 90 solid walls and F 90 lightweight partition walls from 100 mm: One sleeve on each side of the wall.
- For F 90 solid ceilings from 150 mm: One sleeve on the ceiling underside.
- Fire-resistance rating R 90 as per DIN 4102, Part 11.
- For flammable pipes.

#### 2. Advantages

- Suitable for straight ducts up to 160 mm dia., angled ducts up to 125 mm dia. and bushing ducts up to 110 mm.
- Space-saving installation thanks to low sleeve height.
- Can be installed in even the tightest space.
- No loose fastening parts.
- No preassembly.
- Additional 2 to 9 mm noise protection possible.

- Moisture does not impair the function.
- The fire-protection sleeves can be installed without prior training when the installation instructions and permit are observed exactly.
- The spacing between sleeves can be 0 mm.
- Sound decoupling can be improved by using the intumescent strip in the component.

#### 3. Properties

- Absolutely maintenance-free.
- Very easy to handle.
- Can be reused after removal.

#### 4. Notes:

- The smallest possible sleeve must always be selected.
- The sleeve can be mortared in without using an anchor by bending the retaining brackets.
- For special solutions, such as insulated pipes or beverage hoses, please use our sleeve type RK I.
- Precise data and specifications can be found in the approval and installation instructions at [www.wuerth.de/brandschutz](http://www.wuerth.de/brandschutz).

### Notes on installation

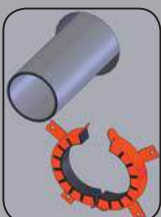

Close the remaining gap between the plastic pipe and the reveal. Place sleeve around the plastic pipe.

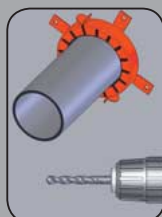

Close the sleeve. Secure the sleeve with an anchor or mortar in the bent-over brackets.

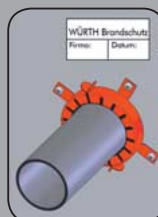

Affix ID plate.

## PIPE COLLAR TYPE RK II

22

Dimensions		
The following dimensions are required for installation of the fire-protection sleeve:		
Plastic pipe outside diameters from 32 to 125 mm.		
Minimum thickness of structural component	Wall partition R 90	Ceiling partition R 90
Masonry	100 mm	-
Concrete, reinforced concrete	100 mm	150 mm
Lightweight partition walls	100 mm	-

Ordering data								
Designation		Dia. in mm inside	Dia. in mm outside	Height in mm	Weight in kg	Number of fastening lugs	Art. No.	P.Qty.
Pipe Collar Type RK II	32	38	47	26.0	0.055	2	<b>0893 304 034</b>	2
	40	46	55	26.0	0.060	2	<b>0893 304 041</b>	2
	50	56	65	26.0	0.070	2	<b>0893 304 051</b>	2
	63	69	82	26.0	0.105	4	<b>0893 304 064</b>	2
	75	81	94	26.0	0.115	4	<b>0893 304 076</b>	2
	90	96	114	26.6	0.210	4	<b>0893 304 091</b>	2
	110	116	134	26.6	0.230	4	<b>0893 304 111</b>	2
	125	132	150	40.0	0.385	4	<b>0893 304 126</b>	2
	140	144	168	40.0	0.425	4	<b>0893 304 141</b>	2
	160	164	188	40.0	0.540	4	<b>0893 304 161</b>	2
180	184	218	40.0	0.770	4	<b>Special order</b>	2	
<b>Mounting kit</b>	(Approval, installation instructions, two ID plates)						<b>0893 304 12</b>	1
<b>W-DN Ceiling Nail</b>	For mounting						<b>0905 364 5</b>	200
<b>W-ZS Quick-Action Anchors</b>	For mounting						<b>0905 365 005</b>	200
<b>Threaded Rod</b>	For mounting						<b>0958 6</b>	1

The information is taken from the current permit and includes nominal dimensions without information on production tolerances.

## INTUMESCENT STRIP AS PIPE PACKING

23



### General Construction Permit/Test Reports

Wall and Ceiling  
Ducts R 90 in Solid  
Structural  
Components  
Z-19.17-1673

Wall and Ceiling  
Ducts  
R 90  
Z-19.17-1922

Building Material  
Approval for  
Intumescent Strip  
Z-19.11-1438

#### 1. Application

- For use in system **F3**
  - Pipe partition I plus/I iso
- For wall and ceiling ducts in solid structural components and light partition walls.
- Fire-resistance rating R 90.
- For flammable pipes of the building material classes B1 and B2,
- I plus: with outside pipe diameter up to 160 mm for walls and 200 mm for ceilings/
- I iso: with outside pipe diameter up to 110 mm in ceilings and walls.
- For pipes made of mineral-reinforced plastics.
- For exact specifications, please always refer to the general construction permit I plus Z-19.17-1673/I iso Z-19.17-1922 and the installation instructions.

- F 90 in solid and light partition walls, wall thickness  $\geq 100$  mm.
- For gaslines in accordance with DVGW worksheet G600.
- F 90 in solid ceilings, ceiling thickness  $\geq 150$  mm.
- For walls, two packings are required, however for ceilings only one packing on underside.

#### 2. Properties

- Absolutely maintenance-free. Can be installed in extremely tight spaces. No drilling or plugging required.
- Extremely elastic material.
- Highly flexible for various pipe diameters.
- Adjacent packings may be installed with distance of 0 mm.
- Water-resistant material.
- Self-adhesive.

#### Note on application



Lay self-adhesive strips around pipe in accordance with approval.



Close off remaining opening with fire-retardant cement without leaving hollow spaces.

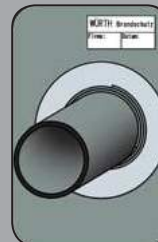

Mount marking plate.

## INTUMESCENT STRIP AS PIPE PACKING

23

Technical Data				
Pipe outside dia. in mm	Installation option I plus	No. of windings I plus Depth 50 mm Thickness per winding: 2 mm	Required length in cm of wall	Required length in cm of ceiling
32	Wall/Ceiling	2	50	25
40	Wall/Ceiling	2	60	30
50	Wall/Ceiling	2	72	36
63	Wall/Ceiling	3	136	68
75	Wall/Ceiling	3	158	79
90	Wall/Ceiling	4	250	125
110	Wall/Ceiling	4	300	150
125	Wall/Ceiling	6	500	250
140	Wall/Ceiling	6	578	289
160	Wall/Ceiling	6	652	326
180	Ceiling	8 x 2	-	987
200	Ceiling	8 x 2	-	1088

Pipe outside dia. in mm	Installation option I iso	Rubber insulation Thickness in mm	No. of windings I iso Depth 50 mm Thickness per winding: 2 mm	Pipes as per permit paragraph
≤ 32	Wall	7 - 27	1	3.2.1
> 32 ≤ 75	Wall	6 - 30	2	3.2.2
> 75 ≤ 110	Wall	6 - 32	3	
≤ 32	Ceiling	7 - 27	1	3.2.1
> 32 ≤ 75	Ceiling	6 - 30	2	
> 75 ≤ 110	Ceiling	6 - 32	4	
≤ 32	Ceiling	7 - 25,5	1	3.2.2
> 32 ≤ 75	Ceiling	6 - 25,5	2	
> 75 ≤ 110	Ceiling	6 - 25,5	4	
≤ 75	Wall/Ceiling	-	1	3.2.1
> 75 ≤ 110	Wall/Ceiling	-	2	3.2.2
≤ 40	Wall/Ceiling	11 - 27	2	3.2.3
> 40 ≤ 110	Wall/Ceiling	12 - 32	4	
≤ 40	Ceiling	-	2	3.2.3
> 40 ≤ 110	Ceiling	-	4	

Ordering Data					
Designation	Length	Width	Thickness	Art. No.	P. Qty.
Intumescent Strip as Pipe Packing	3.57 m	50.0 mm	2.0 mm	0893 304 303	1
Intumescent Strip as Pipe Packing	12.50 m	50.0 mm	2.0 mm	0893 304 302	1
Installation kit for pipe partition I	-	-	-	0893 304 304	1

# 31

## Fire-Retardant Pads



The fire-retardant pads consist of mineral fibreboard strips with a case of non-inflammable continuous-filament glass yarn.

300 x 200 x 40 mm

300 x 200 x 100 mm

Application set



### General construction permit / test reports

Wall and ceiling ducts  
S90  
Z-19.15-1117

#### 1. Application

- For use in system **E**  
– Fire-retardant pads 90 **E**
- For sealing wall and ceiling ducts with a fire-resistance time of S90 according to DIN 4102, Part 9, for cable, cable clusters and cable-support systems.
- Independent of the cross-section involved.
- Suitable for light waves.
- Maximum cable space: 60% of partition size.

#### 2. Advantages

- The pads can be used to provide for planned or unplanned installations at a later date, either as a temporary solution or as a definitive partition.
- Tear-resistant and dust-free pads (suitable for dust-sensitive rooms).
- Easy to install.
- Not sensitive to water, light and frost.

#### 3. Properties

- Seals off fire and combustion gases.
- Non-inflammable.
- Seal off rooms.
- Easy to install.
- Reusable after removal.
- Sound insulating and easy to retrofit .
- Resistant to aging, light weight.

#### 4. Notes

- Cable clusters and retrofitted cables and conduits must be sealed with fire-retardant filler **62**.

### Procedure for use

#### Wall installation



Clean opening.

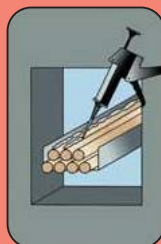

Seal cables and spaces between cables with fire-retardant filler.

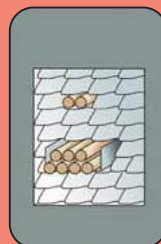

Insert fire-retardant pads.

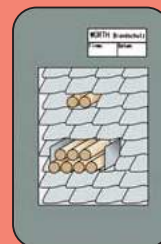

Affix ID plate.

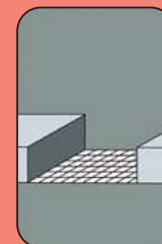

In case of ceiling installation: affix wire mesh. Seal gaps with fire-retardant filler.

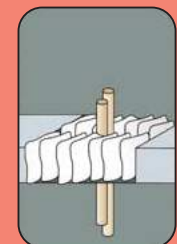

Insert fire-retardant pads. Affix ID plate.

## Dimensions

The following dimensions are required for installation of fire-retardant pads:

	Wall partition	Ceiling partition
<b>Minimum thickness of structural component</b>		
Concrete, light dividing walls	100 mm	150 mm
Masonry	100 mm	–
<b>Max. partition size</b>		
Width	106 cm	60 cm
Height / Length	150 cm	unlimited

## Ordering information

Designation	Dimensions	Art. No.	P. Qty.
<b>Fire-retardant pads</b>	300 x 200 x 40	<b>0893 305 040</b>	10
	300 x 200 x 100	<b>0893 305 100</b>	5
<b>Application set</b>	Permit, installation instructions 2 ID plates	<b>0893 305 1</b>	1

# 32

## Fire Protection Stones/Plugs



grey

SUS 1 Fire Protection Putty



### General construction permit / test reports

Wall and ceiling ducts Fire protection plugs S 90 Z-19.15-1495	Wall and ceiling ducts Fire Protection Stones S 90 Z-19.15-1494	Product approval SUS 1 Fire Protection Putty Z-19.11-1732
--	---	---

### 1. Application

- For use in system **E1**
  - Fire protection stones and plugs **E1**
- Fire protection class S 90 pursuant to DIN 4102, Part 9.
- For wall and ceiling ducts for electrical lines and for copper pipes up to 28 mm in diameter or steel pipes up to 54 mm in diameter (pipes with stones only).

### 2. Advantages

- Easy application, especially suitable for regular small- and medium-size openings or core-drilled holes from 50 to 200 mm.
- Easy subsequent installation, and can be used quickly afterward.
- Dust- and fibre-free. Halogen- and solvent-free.
- Subsequent installation possible at any time.

### 3. Properties

- Fire Protection Plugs are simply selected depending on the diameter of the core-drilled hole and installed in both sides of the wall or ceiling, and the space between cables is closed with the SUS 1 Fire Protection Putty.
- Rectangular openings are closed off with the Fire Protection Stones.
- Only 2 cm (up to 18 mm copper pipe) or 5 cm spacing between pipes necessary.
- Distance from cable to pipes: at least 10 cm.

### Procedure for use



Clean opening.

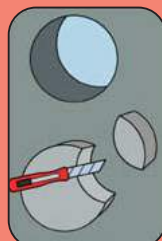

Cut fire protection plugs in accordance with the cable placement.



Affix fire protection plugs on both sides of the wall and fill remaining gap and spaces between cables with SUS 1 Fire Protection Putty.

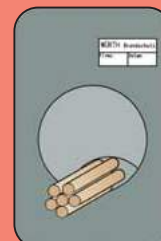

Attach identification plate.

<b>Dimensions</b>	
<b>Fire-resistance rating</b>	<b>S 90</b>
Wall thickness of concrete, masonry and light partition wall	≥ 100 mm
Ceiling thickness	≥ 150 mm
Max. unfinished opening in wall/ceiling with Fire Protection Plugs	max. dia. 310 mm
Max. unfinished opening in wall with Fire Protection Stones	1,000 mm (width) x 500 mm (height)
Max. unfinished opening in ceiling with Fire Protection Stones	500 mm (width) x unlimited length
<b>Partition thickness</b>	
Fire Protection Plugs	≥ 200 mm to dia. 210 mm
Fire Protection Stones	≥ 220 mm
Distance to next partition	≥ 50 mm

<b>Ordering information</b>					
Designation	Dimensions in mm		For core-drilled hole	Art. No.	P. Qty.
	dia. db/da	Height			
<b>Fire Protection Plugs</b>	55/61	70	up to 52 mm	<b>0893 305 401</b>	20
	80/86	70	up to 77 mm	<b>0893 305 402</b>	20
	110/116	70	up to 107 mm	<b>0893 305 403</b>	20
	136/142	70	up to 132 mm	<b>0893 305 404</b>	20
	162/168	70	up to 158 mm	<b>0893 305 405</b>	20
	206/212	70	up to 202 mm	<b>0893 305 407</b>	20
<b>Fire Protection Stones</b>	130 x 220 x 50 mm			<b>0893 305 410</b>	20
<b>SUS 1 Fire Protection Putty</b>	310 ml cartridge			<b>0893 305 417</b>	1/12
<b>Mounting set</b>	Fire Protection Plugs/Stones			<b>0893 305 416</b>	1

# FIRE RESISTING FOAM 90

35



white

Mounting kit



## General construction permit/test reports

Wall and ceiling ducts  
S 90  
Z-19.15-1472

Wall and ceiling ducts  
R 90  
Z-19.17-1773

### 1. Area of use

- For use in the system **D1**
- Fire Protection Foam 90 **D1**
- For wall and ceiling ducts with a fire-resistance time of S 90 according to DIN 4102, Part 9 for cables, cable bundles and cable support systems.  
For wall and ceiling ducts with a fire-resistance time of R 90 according to DIN 4102, Part 11 for flammable and non-flammable pipes.
- For walls and ceilings up to a maximum opening size of 500 cm<sup>2</sup>. The maximum height of 20 cm or maximum width of 50 cm may not be exceeded here.  
An opening diameter of 25 cm may not be exceeded for R 90 pipe ducts.

### 2. Advantages

- Fast, simple sealing.
- Especially well-suited for retrofitting.
- Installation depth just 15 cm.
- No coating of cables below a diameter of 20 mm is necessary. Coat cables larger than 20 mm with Art. No. 0893 303 006.
- Flammable pipes must be installed with the Würth intumescent strip according to Permit Z-19.17-1773.

68

### 3. Properties

## Product Range Case



Art. No. 0893 303,105

ORSY

- Always shake the can thoroughly.
- Processing temperature of can minimum 15°C to 30°C.
- Yield: approx. 900 cm<sup>3</sup>, density: approx. 0.5 g/cm<sup>3</sup>.
- Hardening time: approx. 1 hour.
- Shelf life 1 year, even when used repeatedly.
- Molded parts can be cut to size as desired.
- **When can has been opened, clean valve with Silicone Remover Art. No. 0893 222 600 and shake out.**
- **Change adapter if work is interrupted for longer than 5 minutes.**
- Only for solid parts (with S 90 cable partitions).  
With R 90 pipe partitions, can also be used in light partition walls.

## Note on processing

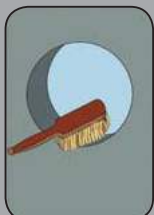

Clean opening.

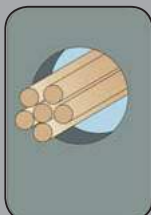

Apply fire-resistant foam 90 (optionally, introduce molded part).

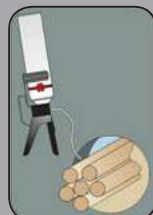

Smooth the surface.



Affix the ID plate.

<b>Dimensions</b>		
<b>Dimensions</b>	<b>S 90</b> according to Z-19.15-1472	<b>R 90</b> according to Z-19.17-1773
<b>Wall thickness</b>	≥ 100 mm	≥ 100 mm
<b>Ceiling thickness</b>	≥ 150 mm	≥ 150 mm
<b>Maximum unfinished opening</b>	≤ 500 cm <sup>2</sup> , however not higher than 20 cm or wider than 50 cm	≤ 500 cm <sup>2</sup> , however not higher than 20 cm or wider than 50 cm, or dia. ≤ 25 cm
<b>Installation depth</b>	≥ 150 mm	≥ 150 mm

<b>Technical data</b>	
<b>Shelf life</b>	12 months
<b>Application temperature</b>	can/environment ≥ 15°C to 30°C/≥ 0°C

<b>Installation of flammable pipes with Würth intumescent strips</b>	
<b>Pipe outside dia.</b>	<b>No. of windings</b>
Dia. ≤ 32 mm	1 layer
32 mm ≤ dia. ≤ 75 mm	3 layers
75 mm ≤ dia. ≤ 110 mm	4 layers

<b>Ordering information</b>			
<b>Designation</b>	<b>Package format / Contents</b>	<b>Art. No.</b>	<b>P. Qty.</b>
<b>Fire resisting foam 90</b>	600 ml can	<b>0893 303 100</b>	1/12
<b>Valve pliers</b>	always use	<b>0893 303 101</b>	1
<b>Spraying tube</b>	350 mm long	<b>0893 303 102</b>	3
<b>Mounting set</b>	Poly bag, 2 marking plates, approval and installation instructions	<b>0893 303 103</b>	1
<b>Moulded part</b>	BS2 150 x 180 x 80	<b>0893 303 106</b>	2
<b>Carrying case set</b>	3 cans, valve pliers + spraying tubes	<b>0893 303 105</b>	1
<b>Silicone remover</b>	600 ml can	<b>0893 222 600</b>	1

# 36

# Fire Resisting Foam BS 2K



### General construction permit/test reports

System Approval Fire Resisting Foam 2-comp. intumescent, System D3 S90 Z-19.15-1722	Product Approval for Fire Protection Foam BS 2K Z-19.11-1717	Pipe Partition R90 AbP P-3167/6595-MPA BS
---	--	---

Assortment case

Art. No. 0893 303 153



### 1. Application

- For use in system **D3**
- Fire resisting foam 2-comp. intumescent **D3**
- For solid wall and ceiling and for light partition wall of fire resistance duration S90 according to DIN 4102 Part 9.
- For partitioning electrical cables in accordance with permit and for flammable pipes up to 32 mm dia. or non-flammable pipes up to 160 mm dia. in accordance with LAR 2005.
- Electrical installation pipes up to 20 mm dia. with and without filling, see permit.

### Note on application



Clean opening (dry, dust and grease-free).



Fill gap with foam without pump interruption.



Cut off protruding material. Affix ID plate.

### Technical data

- The fire resisting foam achieves a yield of approx. 2 litres at +20°C.
- It foams up additionally in case of a fire (intumescent).
- The recommended application temperature is between +15°C and +30°C, ideally +20°C to +25°C.
- Storage and transport temperature between +5°C and +25°C.
- Reaction time approx. 10 seconds.
- Can be cut after approx. 30 seconds.
- Later additions possible.
- Absolutely dust and fibre-free.
- Solvent and halogen-free, no softener.
- Cartridge can be used repeatedly.

### Ordering information

Designation	Package format/ contents	Art. No.	P. Qty.
<b>Fire resisting foam BS 2K</b>	Cartridge 380 ml, incl. 2 mixers, 1 extension and assembly instructions	<b>0893 303 150</b>	1/12
<b>Application gun BS 2K 2:1</b>	–	<b>0893 303 151</b>	1
<b>Replacement mixer</b>	4 mixers, 2 extensions	<b>0893 303 152</b>	4
<b>ID plate</b>	Length: 140 mm / height: 80 mm	<b>0893 310 004</b>	20

# CABLE BOX

38



With plastic cover/foam strips

Cable box

Mounting kit

Fastening material



## General construction permit/test reports

Cable box, type short  
S 90/S 30 wall ducts  
Z-19.15-1428

Cable box, type long  
S 90 wall and ceiling  
ducts  
Z-19.15-1429

### 1. Area of use

- For installation in system **B1**  
Fire-resistance class S 90 (long and short types) or S 30 (short type) as per DIN 4102.
- Cables and electrical lines may be routed through the cable partition. The cable box may be installed in at least 10 cm-thick solid walls, at least 15 cm-thick solid ceilings (type long only) and in at least 10 cm-thick light partition walls.

### 2. Advantages

- Cables can be retrofitted very easily, as no filling of the box interior is required. Only sealing off of the cover against combustion gases is necessary.
- With cable installations that already exist, the box can be retrofitted without a great deal of effort by removing the upper side of the box.
- No dust or dirt is produced by retrofitting cables.
- Also suitable for hollow-core cables, coaxial cables, bundled tubes and fiber-optic cables.

### 3. Features

- The sheet-metal housing is installed in the unfinished opening with cement mortar or plaster.
- Alternatively, the EASY Cable Boxes may be installed with the PURlogit® EASY Installation Foam.
- The cable box can be filled 100% with cables.
- Finally, tailor both covers/foam strips accordingly and seal off the remaining gaps with silicone/PURlogit® EASY Foam so that it is smoke-proof.

### 4. Notes:

- Individual lines of steel, copper or plastic tubing for control purposes with a maximum outside diameter of 15 mm may be routed through. Up to three boxes next to one another and up to seven over one another are possible (for mortar laying and long type).
- Cable support structures such as cable channels or platforms may not be routed through the cable partition.**
- As subsequent installation precaution, plastic tubes up to max. M 63 (long type) or M 40 (short type) are used.
- If the long type is installed in light partition walls, please use an installation frame.
- Please do not install any construction materials such as mortar** or mineral wool inside the box.

Long type: For universal use,

Short type: Especially suitable for thin walls, as the cable box is only 12.5 cm or 15 cm (EASY version) long.

### Notes on installation



Clean opening and pre-wet part reveal.



Install the cable boxes with fire-resistant cement or the EASY Cable Box using PURlogit® EASY Installation Foam.

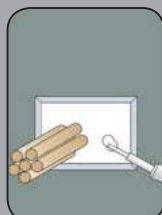

Tailor cover for cable laying or fit foam strips into the cable box.



Seal cover and remaining gap with silicone. Alternative for EASY Cable Box: PURlogit® EASY.

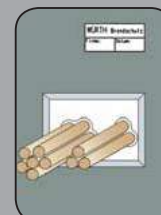

Attach ID plate.

## CABLE BOX

38

Dimensions					
Type Long		Type Short			
Fire-resistance rating	S 90	Fire-resistance rating	S 90	S 30	
Solid wall thickness	≥ 10 cm	Solid wall thickness	≥ 12.5 cm	≥ 10 cm	≥ 10 cm
Ceiling thickness, solid	≥ 15 cm	Suitability for use with ceilings must be proven separately.			
Light partition wall	≥ 10 cm	Light partition wall	≥ 12.5 cm	≥ 10 cm	≥ 10 cm
Partition thickness	≥ 27 cm	Partition thickness	≥ 12.5 cm	≥ 15 cm	≥ 12.5 cm

Ordering information				
Cable box for the installation of fire-retardant cement				
Designation	Dimensions in mm (height x width x depth)	Shape	Art. No.	P. Qty.
Type Long	110 x 120 x 270	rectangular	0893 305 120	1
Type Long	110 x 200 x 270	rectangular	0893 305 200	1
Type Long	110 x 280 x 270	rectangular	0893 305 280	1
Type Long	110 x 435 x 270	rectangular	0893 305 435	1
Type Short	60 x 240 x 125	rectangular	0893 305 240	1
Type Long	110 x 128 x 270	hexagonal	0893 305 128	1
Installation set		cable box	0893 305 305	1
Transparent silicone		310 ml cartridge	0892 530 1	1/12

Ordering information				
Cable box variant EASY (with expanded-graphite strips) for installation with PURlogic® EASY Installation Foam or with fire-retardant cement				
Designation	Dimensions in mm (height x width x depth)	Shape	Art. No.	P. Qty.
Type Long EASY	110 x 120 x 270	rectangular	0893 305 122	1
Type Long EASY	110 x 200 x 270	rectangular	0893 305 202	1
Type Long EASY	110 x 240 x 270	rectangular	0893 305 242	1
Type Long EASY	110 x 280 x 270	rectangular	0893 305 282	1
Type Long EASY	110 x 335 x 270	rectangular	0893 305 335	1
Type Short EASY	60 x 240 x 150	rectangular	0893 305 152	1
Type Long EASY	80 x 270	round	0893 305 082	1
Type Long EASY	110 x 270	round	0893 305 112	1
EasyFoam Foam Panel	500 x 300 x 40		0893 305 306	2
PURlogic® EASY Foam		500 ml can	0892 143	20

# 41 Mineral Fibre-Board



with Intumescent Coating

1000 x 600 x 50 mm **C**

1000 x 600 x 80 mm **C1**

Application set



## General construction permit / test reports

System approval for fire partition W combination system <b>C</b> S90 Z-19.15-1413	System approval for fire partition W1 system <b>C1</b> S90 Z-19.15.1493
--	--

### 1. Application

- For use in system **C + C1**
  - Combination fire partition W **C**
  - Fire partition W1 **C1**
- For cable and pipe partitions with a fire-resistance time of S90 in solid ceilings and walls as well as in walls of light-weight construction.

### 2. Advantages

- Especially for light dividing walls F90.
- Easy to apply.
- Excellent sound-protection properties.

### 3. Properties

- Pre-coated mineral fibreboard for quick and easy installation.
- Non-combustible mineral fibreboard (building materials class DIN 4102 - A).
- Unfinished density 150 kg/m<sup>3</sup>.
- Seals off fire and combustion gases.

### Procedure for use



Clean opening. Do not moisten.



Mix fire-retardant coating and fire-retardant filler.

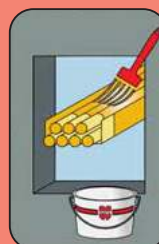

Apply fire-retardant coating to cable-support system and cables.

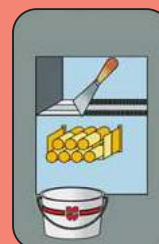

Apply fire-retardant filler to structural reveals and to the cut edges, insert mineral fibre-boards.

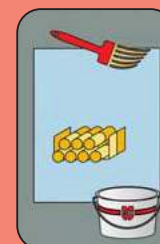

Finally, coat the partition surface, the cables and the cable-support systems with fire-protective coating (at least 1 mm thick).

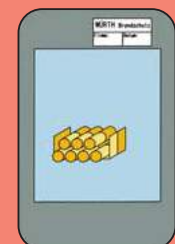

Affix ID plate.

### Ordering information

Designation	Dimensions in mm	Art. No.	P. Qty.
Mineral fibreboard with one-sided intumescent coating	1000 x 600 x 50	<b>0893 308 2</b>	3
Mineral fibreboard with two-sided intumescent coating	1000 x 600 x 80	<b>0893 308 80</b>	2
Application set	Permit, installation instructions, 2 ID plates	<b>0893 308 1</b>	1

# FLEXEN® STONE WOOL

42



Stone-wool insulation with grid-reinforced, tear-resistant aluminium lamination

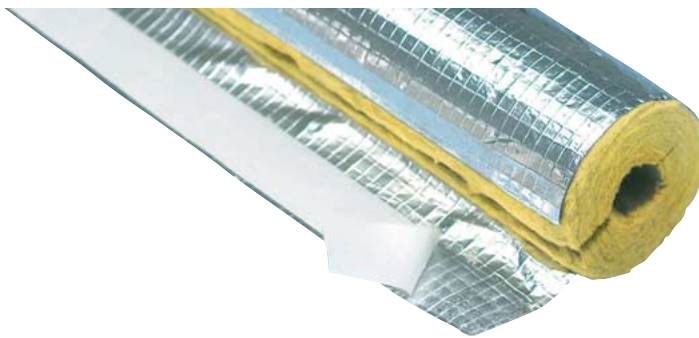

## 1. Application

- For use in system **A** + **C** + **D1** + **H**
  - Combination partition **A**
  - Fire partition W combination **C**
  - Fire resisting foam 90 **D1**
  - Pipe partition Z **H**
- For non-combustible, water- and sewage-bearing pipes.
- To insulate heating- and utility-water pipes, solar installations, hot-water and steam pipes.

## 2. Advantages

- Easy installation due to indented inner lining.
- Noise neutralisation and linear expansion provided by insulation.

## 3. Properties

- Non-combustible, class A2, DIN 4102.
- Heat resistant up to 250°C (woollen-sided)
- Melting point 1000°C.
- Pressure resistant and dimensionally stable.
- Free of corrosive materials.

## Procedure for use

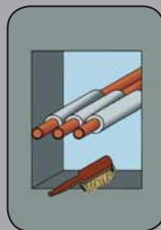

Clean opening.



Moisten reveal.



Mix and apply fire-protection cement.



Affix ID plate.

Ordering information												
Designation	Copper pipes (CU)					FLEXEN® Stone Wool 035/040 Application: fire protection			Brandschott W-Kombi (System C)***			
	Steel pipes (FE)		Combination partition 90 (System A)**			Brandschott W-Kombi (System C)***						
	Outside dia. in mm	Nom. width DN	in inches	Outside dia. in mm	Nom width DN	Insulation thickness in mm	Art. No.	P. m	Insulation thickness in mm	Art. No.	P. m	
FLEXEN® Stone Wool	15	-	1/4	13,5	8	30	0871 130 015	25	-	-	-	
	18	15	3/8	17,2	10	30	0871 130 018	25	-	-	-	
	22	20	1/2	21,3	15	30	0871 130 022	20	-	-	-	
	28	25	3/4	26,9	20	30	0871 030 028	20	-	-	-	
	35	32	1	33,7	25	30	0871 030 035	16	-	-	-	
	42	40	1 1/4	42,4	32	30	0871 030 042	12	40	0871 040 042	9	
	-	-	1 1/2	48,3	40	40*	0871 040 048	9	40	0871 040 048	9	
	54	50	2	60,3	50	-	-	-	40	0871 140 060	6	
	76,1	65	2 1/2	76,1	65	-	-	-	44	0871 340 076	5	
	54	50	-	54,0	-	50	0871 050 054	5	50	0871 050 054	5	
57	50	2	60,3	50	60	0871 060 060	4	60	0871 060 060	4		

\* This size is not available in the 30 mm insulator thickness.

\*\* See fire-protection documentation „Combination Partition 90“ construction permit Z-19.15-1333.

\*\*\* See fire-protection documentation „W-Combination Partition 90“ construction permit Z-19.15-1413.

## MINERAL WOOL A1 (ROCK WOOL / STUFFING WOOL)

43



**Building material class A1**  
Melting point: 1000 °C

**packed loose**  
Sack: 10 kg



### 1. Application

- For working in the system **D2 + G + J**
  - Intumescent Cable Partition **D2**
  - Pipe partition E **G**
  - Joint system E **J**
- For non-combustible, water-bearing and sewage-bearing pipes.
- To insulate heating water and utility water pipes, solar installations, hot water and steam pipes.
- For insulating fire protection glazing.

### 2. Advantages

- Specially suited for sealing pipes subject to thermal change and mechanical motion.

### 3. Properties

- Non-combustible A1, DIN 4102.
- Temperature range up to +800 °C.
- Melt temperature from +1000 °C.

### Working notice

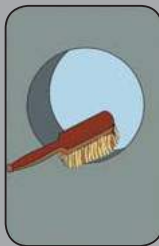

Clean opening.

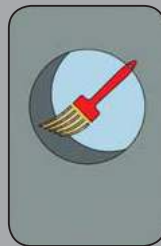

If required, apply primer coat for silicone.

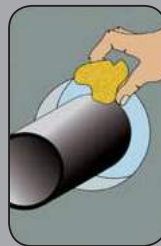

Stuff mineral wool into the partition.

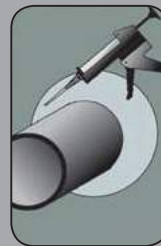

Fit the elastic fireproof seal B1.

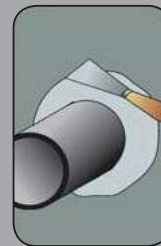

Smooth the sealant.



Affix ID plate.

### Ordering Data

Designation	Contents	Art. No.	P. Qty.
Mineral wool A1	10 kg	<b>0874 110 014</b>	1

## FLEXEN® MINERAL WOOL MATS

44



Mineral wool mat with grid-reinforced, tear-proof aluminium lamination



### 1. Application

- For use in system **A** + **D1** + **G2** + **H**
  - Combination partition **A**
  - Fire resisting foam 90 **D1**
  - Pipe partition dB **G2**
  - Pipe partition Z **H**
- For water and sewage bearing pipes.
- To insulate heating-water and utility-water pipes, solar installations, hot-water and steam pipes.

### 2. Advantages

- Noise neutralisation and linear expansion provided by insulation

### 3. Properties

- Non-flammable A2, DIN 4102, behaviour in fire (DIN 4102), Construction Material Class A2, non-flammable according to building permit Z-23.14-1115.
- Heat resistant up to 250°C.
- Melting temperature > +1000°C.
- Unfinished density 40 kg/m<sup>3</sup>.
- Pressure resistant and dimensionally stable.
- Free of corrosive materials.
- Aluminium lamination acts as a vapour barrier.
- Water-repellent.
- Chemically neutral.

### Ordering information

Designation	Insulating thickness in mm	Width in mm	Length in m	Contents of carton m <sup>2</sup>	Art. No.	P. Qty./m <sup>2</sup>
<b>FLEXEN®</b> <b>Rock wool mats</b>	20	500	10	2 mats, each 5 m <sup>2</sup> = 10 m <sup>2</sup>	<b>0871 200 020</b>	10
	30	500	8	2 mats, each 4 m <sup>2</sup> = 8 m <sup>2</sup>	<b>0871 200 030</b>	8
	40	500	6	2 mats, each 3 m <sup>2</sup> = 6 m <sup>2</sup>	<b>0871 200 040</b>	6

## FLEXEN® COLD RUBBER PLUS

48



### 1. Application

- For use in system **H1** + **H2** + **H3**
  - Pipe Partition KL **H1**
  - Pipe Partition Intumescent Matt Plus **H2**
  - Pipe Partition Intumescent Strip Plus **H3**
- For the insulation of refrigerators/air conditioners.

### 2. Properties

Technical data								
Properties	Description/Data							
Material	Closed-cell foam based on synthetic rubber. CFC-, HCFC-, formaldehyde-, cadmium- and silicone-free							
Color	Black							
Dimensions	2 m hoses, 2 m self-adhesive hoses, continuous hoses, continuous plates							
Medium temperature	Max. +105°C (continuous plates: +85°C) Min. -50°C							
Heat conductivity	°C	-30	-20	0	+10	+20	+40	+70
	W/(m x K)	0.030	0.031	0.033	0.034	0.035	0.037	0.040
Water vapor diffusion resistance value	≥ 10,000 μ							
Fire behavior	Flame-resistant B <sub>1</sub> -s3, d0 (hose), B-s3, d0 (plate), self-extinguishing, does not spread fire, does not drip, in compliance with construction permits Z-56-269.35 ff.							
Risk of corrosion	Corresponds to DIN 1988 Part 7, does not contain substances aggressive to metals							

### 3. Advantages

- Low heat conductivity.
- High water vapor diffusion resistance.
- Highly flexible.
- Professional angled cuts  
→ Optimum adhesion of self-adhesive hoses.

# FLEXEN® COLD RUBBER PLUS

48

## 2 m hose delivery overview

Copper tube (Cu)		Steel tube (Fe)			Insulation layer thickness 1			Insulation layer thickness 2			Insulation layer thickness 4		
Outside dia. in mm	Nominal width DN	in inches	Outside dia. in mm	Nominal width DN	Insul. thckn. in mm	Art. No.	P. Qty. in m	Insul. thckn. in mm	Art. No.	P. Qty. in m	Insul. thckn. in mm	Art. No.	P. Qty. in m
6	4	-	-	-	7.0	5258 501 006	466	9.5	5258 502 006	288	-	-	-
8	6	-	-	-	7.0	5258 501 008	406	10.0	5258 502 008	240	-	-	-
10	8	1/8	10.2	6	7.5	5258 501 010	284	11.0	5258 502 010	192	15.5	5258 504 010	110
12	10	-	12.5	-	7.5	5258 501 012	234	11.0	5258 502 012	168	16.0	5258 504 012	100
15	10	1/4	13.5	8	8.0	5258 501 015	192	11.0	5258 502 015	144	17.0	5258 504 015	90
18	15	3/8	17.2	10	8.0	5258 501 018	168	11.5	5258 502 018	120	17.5	5258 504 018	72
22	20	1/2	21.3	15	8.5	5258 501 022	132	12.0	5258 502 022	96	18.0	5258 504 022	64
28	25	3/4	26.9	20	8.5	5258 501 028	96	12.5	5258 502 028	80	19.0	5258 504 028	50
35	32	1	33.7	25	9.0	5258 501 035	70	13.0	5258 502 035	60	19.5	5258 504 035	40
42	40	1 1/4	42.4	32	9.0	5258 501 042	60	13.5	5258 502 042	40	20.0	5258 504 042	32
-	-	1 1/2	48.3	40	-	-	-	13.5	5258 502 048	40	20.5	5258 504 048	24
54	50	-	54.0	-	-	-	-	13.5	5258 502 054	32	21.0	5258 504 054	24
57	50	-	57.0	-	-	-	-	13.5	5258 502 057	32	21.0	5258 504 057	20
-	-	2	60.3	50	-	-	-	14.0	5258 502 060	32	21.5	5258 504 060	20
64	-	-	63.5	-	-	-	-	14.0	5258 502 064	28	21.5	5258 504 064	18
70	-	-	70.0	-	-	-	-	14.0	5258 502 070	28	22.0	5258 504 070	16
76.1	65	2 1/2	76.1	65	-	-	-	14.0	5258 502 076	28	22.0	5258 504 076	16
89	80	3	88.9	80	-	-	-	14.5	5258 502 089	20	22.5	5258 504 089	12
108	100	-	108.0	-	-	-	-	14.5	5258 502 108	16	23.0	5258 504 108	10
114	100	4	114.3	100	-	-	-	15.0	5258 502 114	16	23.5	5258 504 114	10

## 2 m self-adhesive hose delivery overview

Copper tube (Cu)		Steel tube (Fe)			Insulation layer thickness 1			Insulation layer thickness 2			Insulation layer thickness 4		
Outside dia. in mm	Nominal width DN	in inches	Outside dia. in mm	Nominal width DN	Insul. thckn. in mm	Art. No.	P. Qty. in m	Insul. thckn. in mm	Art. No.	P. Qty. in m	Insul. thckn. in mm	Art. No.	P. Qty. in m
15	10	1/4	13.5	8	8.0	5258 601 015	192	11.0	5258 602 015	144	17.0	5258 604 015	90
18	15	3/8	17.2	10	8.0	5258 601 018	168	11.5	5258 602 018	120	17.5	5258 604 018	72
22	20	1/2	21.3	15	8.5	5258 601 022	132	12.0	5258 602 022	96	18.0	5258 604 022	64
28	25	3/4	26.9	20	-	-	-	12.5	5258 602 028	80	19.0	5258 604 028	50
35	32	1	33.7	25	-	-	-	13.0	5258 602 035	60	19.5	5258 604 035	40
42	40	1 1/4	42.4	32	-	-	-	13.5	5258 602 042	40	20.0	5258 604 042	32
-	-	1 1/2	48.3	40	-	-	-	13.5	5258 602 048	40	20.5	5258 604 048	24
54	50	-	54.0	-	-	-	-	13.5	5258 602 054	32	21.0	5258 604 054	24
-	-	2	60.3	50	-	-	-	14.0	5258 602 060	32	21.5	5258 604 060	20
76.1	65	2 1/2	76.1	65	-	-	-	14.0	5258 602 076	28	22.0	5258 604 076	16
89	80	3	88.9	80	-	-	-	14.5	5258 602 089	20	22.5	5258 604 089	12

## Continuous hose delivery overview

Copper tube (Cu)		Steel tube (Fe)			Insulation layer thickness 1			Insulation layer thickness 2		
Outside dia. in mm	Nom. width DN	in inches	Outside dia. in mm	Nom. width DN	Insul. thckn. in mm	Art. No.	P. Qty. in m	Insul. thckn. in mm	Art. No.	P. Qty. in m
6	4	-	-	-	7.0	5258 701 006	76	9.5	5258 702 006	68
8	6	-	-	-	7.0	5258 701 008	74	10.0	5258 702 008	62
10	8	1/8	10.2	6	7.5	5258 701 010	70	11.0	5258 702 010	35
12	10	-	12.5	-	7.5	5258 701 012	60	11.0	5258 702 012	35
15	10	1/4	13.5	8	8.0	5258 701 015	55	11.0	5258 702 015	35
18	15	3/8	17.2	10	8.0	5258 701 018	40	11.5	5258 702 018	27
22	20	1/2	21.3	15	8.5	5258 701 022	32	12.0	5258 702 022	24
28	25	3/4	26.9	20	8.5	5258 701 028	27	12.5	5258 702 028	20

## Continuous plate delivery overview

Insul. thckn. in mm	Dimensions Width in m	Length in m	Art. No.	P. Qty. in m <sup>2</sup>
6	1	18	5258 800 006	18
10	1	10	5258 800 010	10
13	1	8	5258 800 013	8
19	1	6	5258 800 019	6
25	1	4	5258 800 025	4
32	1	3	5258 800 032	3

## Self-adhesive continuous plate delivery overview

Insul. thckn. in mm	Dimensions Width in m	Length in m	Art. No.	P. Qty. in m <sup>2</sup>
6	1	18	5258 800 106	18
10	1	10	5258 800 110	10
13	1	8	5258 800 113	8
19	1	6	5258 800 119	6
25	1	4	5258 800 125	4
32	1	3	5258 800 132	3

51

# Elastic Fire-Retardant Sealant B1



gray/white

Silicone-Primer



## General construction permit / test reports

For general B1 requirements P-MPA-E-00-583

### 1. Application

- For use in system
  - Pipe partition E
  - Joint system E
  - Joint system P

**G** + **J** + **L**  
**G**  
**J**  
**L**

- To seal expansion joints and connecting joints subject to expansion strain with a fire-resistance time of F 90 according to DIN 4102, Part 2.
- Between sheet metal and/or solid building materials.
- For sealing fire-retardant glass

### 2. Advantages

- Easy to apply.

### 3. Properties

- Flame resistant according to DIN 4102, Part 2, B1.
- Resistant to ageing, non-odorous, UV-resistant, permanently elastic.
- Color gray similar to RAL 7037, color white similar to RAL 9003.

### 4. Notes

Sealant must be smoothed with a neutral smoothing agent such as our sealant smoothing agent, Art. No. 0893 3. Joint finishing should be oriented on DIN 18540 and DIN 18545. The sealant must only be subject to 2-side adhesion. Any additional adhesion to an undersurface can result in stress cracks in case of movement so that 100% sealing is no longer maintained. To prevent 3-side adhesion, the joint should be packed with back-fill material. The minimum depth of 15 mm must be provided on both sides of the partition.

## Procedure for use

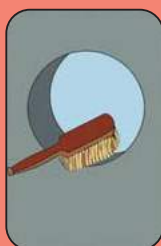

Clean opening.

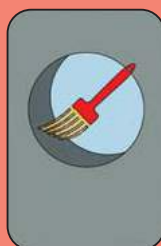

If required, apply Silicone-Primer.

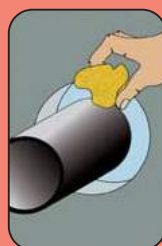

Stuff mineral wool into the partition.

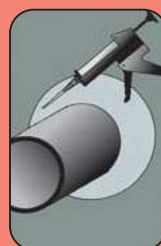

Apply elastic fire-retardant sealant B1.

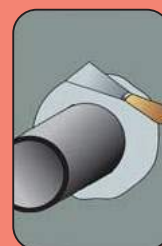

Smooth sealant.

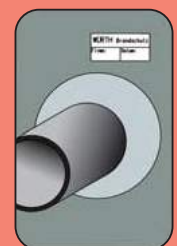

Affix ID plate.

### Dimensions

<b>Joint width</b>	10 mm	20 mm	30 mm
<b>Silicone application depth</b>	15 mm	15 mm	15 mm
<b>Wall thickness</b>	≥ 100 mm	≥ 100 mm	≥ 100 mm

### Technical data

<b>Base raw material</b>	silicone rubber / oxime vulcanising
<b>Shelf life</b>	9 months at a maximum temp. of +25°C
<b>Prime coat on absorbent surfaces</b>	with primer Art. No. 0892 170
<b>Temperature resistance after hardening</b>	-50°C to +150°C
<b>Resistant to</b>	ozone, weather, UV radiation, saltwater, fats, oils, standard cleaning agents
<b>Resistant to brief exposure to</b>	dissolved lyes and acids
<b>Elasticity</b>	20% of joint width
<b>Skin formation time</b>	about 10 minutes
<b>Hardening time</b>	2 mm on first day (+23°C / 50% relative humidity)
<b>Recovery</b>	> 90% (ISO 7389)
<b>Elongation at rupture</b>	210% (ISO 8389)
<b>Shore A hardness</b>	20°
<b>Specific weight</b>	1.4 g/ml

### Chemical stability

Long-term resistance	Short-term resistance	No resistance
Acetone	Petrol	Acetic acid (25%)
Ethanol (20%)	Acetic acid (10%)	Ether
Isopropanol	Light gasoline	Sodium hydroxide solution (concentrated)
Sodium carbonate solution (20%)	Hydrochloric acid (10%)	Phosphoric acid (concentrated)
Sodium hydroxide solution (10%)	Sulphuric acid (5%)	Nitric acid (10%)
Paraffinic oil	Toluene	
	Trichloroethane	
	Trichloroethylene	

### Ordering information

Designation	Colour	Package format / Contents	Art. No.	P. Qty.
<b>Elastic fire-retardant sealant B1</b>	grey	Cartridge 310 ml	<b>0893 301</b>	1/12
<b>Elastic fire-retardant sealant B1</b>	white	Cartridge 310 ml	<b>0893 301 001</b>	1/12
<b>Silicone-Primer</b>	-	Bottle 250 ml	<b>0892 170</b>	1/10
<b>Sealant Smoothing Agent</b>	-	Canister 5 l	<b>0893 3</b>	1

# 62

# Fire-Retardant Filler



intumescent

Cartridge 310 ml



## General construction permit / test reports

System approval for combination partition System <b>A</b> Z-19.15-1333	System approval for fire partition M System <b>B</b> Z-19.15-1290 + Z-19.15-821	System approval Intumescent cable partition System <b>D2</b> Z-19.15-1483	System approval with fire-retardant pads 90 System <b>E</b> Z-19.15-1117	Product approval Fire-retardant filler Z-19.11-1116
--	--	---	--	--

### 1. Application

- For use in system **A + B + D2 + E + G1**
  - Combination partition **A**
  - Fire partition M **B**
  - Intumescent cable partition **D2**
  - Fire-retardant pads 90 **E**
  - Intumescent pipe partition **G1**
- For sealing cable gussets in fire-retardant pad system 90.
- To seal part openings and openings for retrofitting in fire-retardant mortar.
- Sealing cable ducts.

### 2. Advantages

- Fast, simple sealing of part openings.
- Particularly suitable for retrofitting and sealing in the pad-partition system.
- One component.
- Free of halogens and solvents.
- Simple application from cartridge.

### 3. Properties

- Building material in accordance with DIN 4102, Part 1, B2.
- Seals off fire and combustion gases.
- Seals off rooms.
- Foams in case of fire.
- Resistant to aging.

### 4. Notes

- The application temperature should not be below +5°C.
- Application time about 6 hours.
- Shelf life: frost free, 12 months, standing.
- This sealant must not be used in rooms subject to moisture.
- Must not be applied if the sealant is exposed to heavy rain, successive frost and thawing, UV radiation or condensation water.
- Must not be painted over since the paint coat would hamper foaming in case of fire.

### Procedure for use

#### with fire-retardant pads



Clean opening.



Seal cables and spaces between cables with fire-retardant filler.

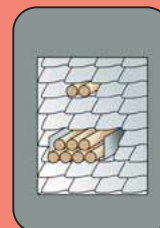

Insert fire-retardant pads.

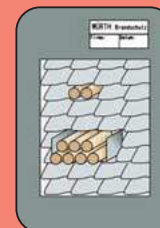

Affix ID plate.

### Technical data

<b>Density</b>	1,200 kg/m <sup>3</sup>
<b>Proportion of non-volatile ingredients</b>	60%
<b>Loss of mass from heating</b> tested at 400°C for 30 minutes	66%
<b>Foam height</b> tested at 400°C for 30 minutes without weight load with samples of 2.0 mm thickness (dry)	75 mm

### Ordering information

Designation	Package format / Contents	Art. No.	P. Qty.
<b>Fire-retardant filler</b>	Cartridge 310 ml	<b>0893 306</b>	1/12
<b>Application set</b>	Fire-retardant pads	<b>0893 305 1</b>	1
<b>Application set</b>	Intumescent cable partition	<b>0893 306 1</b>	1

# 63

## Fire-Retardant Coating



### General construction permit / test reports

System approval for fire partition W combination System <b>C</b> Z-19.15-1413	Product approval Fire-retardant coating Z-19.11-1389	System approval for fire partition W1 System <b>C1</b> S90 Z-19.15-1493
---	---	---

### 1. Application

- For use in system **C** + **C1** + **D1**
  - Fire partition W combination **C**
  - Fire partition W1 **C1**
    - Fire resisting foam 90 **D1**
- Intumescent, dispersion-based coating for multi-purpose application.

### 2. Advantages

- Easy application with brush, roller or spray gun.

### 3. Properties

- Foams in case of fire.
- Permanently elastic.
- Resistant to aging.

### 4. Notes

- This sealant must not be used in rooms subject to moisture.
- Must not be applied if the sealant is exposed to heavy rain, successive frost and thawing, UV radiation or splash water.
- Must not be painted over since the paint coat would hamper foaming in case of fire.
- Storage: frost free, 12 months.

### Procedure for use



Clean opening.

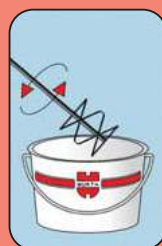

Mix fire-retardant coating.

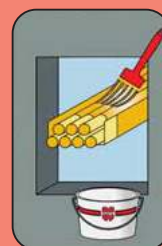

Coat cable-support system and cables with fire-retardant coating.



Insert mineral fibreboards. Finally, coat the partition surface, the cables and the cable-support systems with fire-retardant coating (at least 1 mm thick).

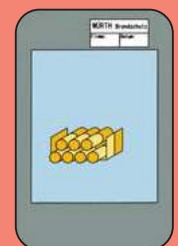

Affix ID plate.

### Technical data

<b>Unfinished density</b>	about 1.30 kg/dm <sup>3</sup>
<b>PH value</b>	about 7.5
<b>Viscosity</b>	about 30,000 mPa S

### Yield

- The information on required amounts are approximate indications calculated without cable.
- The exact consumption depends on the size of the opening, cable quantity and the number of cable routes.
- For an opening of 1 m<sup>2</sup> about 3.0 kg of fire-retardant coating will be needed.

### Ordering information

Designation	Colour	Package format / Contents	Art. No.	P. Qty.
<b>Fire-retardant coating</b>	white	Bucket 15 kg	<b>0893 303 015</b>	1
<b>Fire-retardant coating</b>	white	Bucket 6 kg	<b>0893 303 006</b>	1
<b>Application set</b>	–	Poly bag, permit, application instructions, 2 ID plates	<b>0893 308 1</b>	1

64

# Fire-Retardant Filling Material



## General construction permit / test reports

System approval for fire partition W combination System <b>C</b> Z-19.15-1413	Product approval Fire-retardant filling material Z-19.11-1388	System approval for fire partition W1 System <b>C1</b> S90 Z-19.15-1493
---	--	---

### 1. Application

- For use in system **C** + **C1**
  - Fire partition W combination **C**
  - Fire partition W1 **C1**
- Intumescent, dispersion-based filling material for universal application.

### 2. Advantages

- Easy-to-apply filler.

### 3. Properties

- Foams in case of fire.
- Permanently elastic.
- Resistant to aging.

### 4. Notes

- The sealant must not be used in rooms subject to moisture.
- Must not be applied if the sealant is exposed to heavy rain, successive frost and thawing, UV radiation or splash water.
- Must not be painted over since the paint coat would hamper foaming in case of fire.
- Storage: frost free, 12 months.

## Procedure for use



Clean opening.

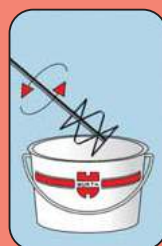

Mix fire-retardant filling material.

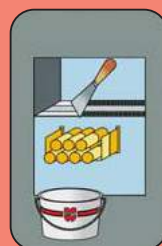

Apply fire-retardant filling material in the reveals and to the cut edges, insert mineral fibreboards.

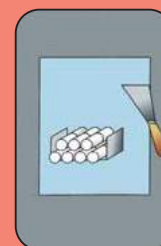

Cover over any projecting material, smooth surface. Apply fire-retardant coating.

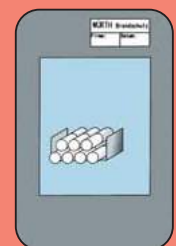

Affix ID plate.

### Technical data

<b>Unfinished density</b>	about 1.35 kg/dm <sup>3</sup>
<b>PH value</b>	about 7.5
<b>Viscosity</b>	about 60 000 mPaS

### Yield

- The information on required amounts is an approximate indication.
- For an opening of 1 m<sup>2</sup> about 4.0 kg of fire-retardant filling material will be needed.

### Ordering information

Designation	Colour	Package format / Contents	Art. No.	P. Qty.
<b>Fire-retardant filling material</b>	white	Bucket 15 kg	<b>0893 306 015</b>	1
<b>Fire-retardant filling material</b>	white	Bucket 6 kg	<b>0893 306 006</b>	1
<b>Fire-retardant filling material</b>	white	Cartridge 310 ml	<b>0893 306 001</b>	1/12
<b>Application set</b>	–	Poly bag, permit, application instructions, 2 ID plates	<b>0893 308 1</b>	1

## FIRE-PROTECTION DUCT I 30 / I 60 / I 90 / I 120

65



**Metal fire-protection duct for encapsulation of fire loads with active fire retardation.**

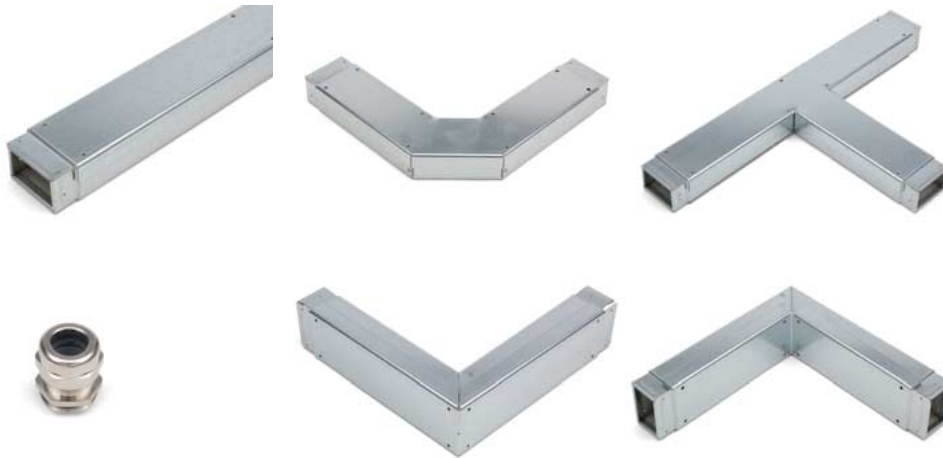

### General Construction Permit/Test Reports

ABP  
General Construction  
Test Certificate  
P-MPA-E-09-011

#### 1. Application

- For installation in the **E4** system
  - Fire-protection duct I 30/I 60/I 90/I 120 for encapsulating fire loads.
- In escape and rescue routes, required hallways and staircases.
- Suitable for cables, flammable pipes and non-flammable pipes with flammable synthetic rubber insulation.

#### 2. Advantages

- No passing on of fire in the duct; actively curtails fire.
- Low space requirement thanks to virtually complete usability of the duct cross-section.
- Fast, simple installation, easily mountable, self-sealing components.
- Dust-free installation.
- Simple fastening even directly on ceilings or walls.
- Duct itself can act as a cable conduit.
- Easily accessible, therefore maintenance-friendly; easy, simple later additions possible.
- Cable outlets with metal or plastic cable glands conforming to EN 60 423 are possible.

- Dimensionally stable.
- The I-duct may be routed through fire-resistant solid and light partition walls.
- Special shapes also available via special order:
  - 1-sided, 2-sided, 3-sided, 4-sided and round duct,
  - Stainless-steel duct,
  - Surfaces in RAL colors.

#### 3. Properties

- Fire-resistance time I 30 to I 120.
- Inner coating begins to react at +200°C.
- Low intrinsic weight.

#### 4. Notes

- With direct contact of the cables and pipes, the permissible total weight resulting from own cable and pipe weight is  $\leq 34$  kg/m.
- Store dry and frost-free.
- The fire-protection duct must be installed while exactly observing the installation instructions and Test Certificate No. P-MPA-E-09-011.

#### Note on application

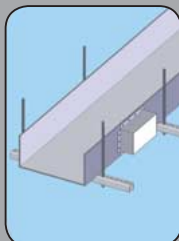

Install fire-protection duct in accordance with the general construction test certificate (ABP), plan and prepare cable outlets..

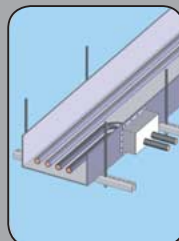



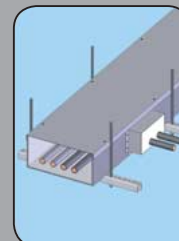





Fill with cables or pipes and close off outlets in accordance with ABP.



Close and screw on cover and execute wall ducts or wall connections in accordance with ABP.

# FIRE PROTECTION DUCT 130 / 160 / 190 / 1120

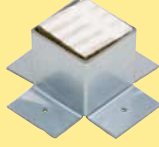
65

Ordering data						
Designation	Width x Height in mm	Weight in kg	Length in mm	degrees	Art. No.	P./m
<b>Duct</b> 	80 x 50	4,15	2.000	-	<b>0973 997 001</b>	2
	200 x 50	7,85	2.000	-	<b>0973 997 002</b>	2
	260 x 100	10,63	2.000	-	<b>0973 997 003</b>	2
	400 x 120	14,76	2.000	-	<b>0973 997 004</b>	2
<b>Flat Square</b> 	80 x 50	1,28	L1 / L2 220 / 220	90°	<b>0973 997 011</b>	1
	200 x 50	2,58	220 / 220	90°	<b>0973 997 012</b>	1
	260 x 100	3,94	220 / 220	90°	<b>0973 997 013</b>	1
	400 x 120	6,10	220 / 220	90°	<b>0973 997 014</b>	1
<b>T-Piece</b> 	80 x 50	3,17	L1 / L2 520 / 220	-	<b>0973 997 021</b>	1
	200 x 50	5,38	640 / 220	-	<b>0973 997 022</b>	1
	260 x 100	8,54	700 / 220	-	<b>0973 997 023</b>	1
	400 x 120	9,17	840 / 220	-	<b>0973 997 024</b>	1
<b>Outer Corner</b> 	80 x 50	1,33	L1 / L2 220 / 220	90°	<b>0973 997 051</b>	1
	200 x 50	2,39	220 / 220	90°	<b>0973 997 052</b>	1
	260 x 100	3,58	220 / 220	90°	<b>0973 997 053</b>	1
	400 x 120	5,15	220 / 220	90°	<b>0973 997 054</b>	1
<b>Inner Corner</b> 	80 x 50	1,35	L1 / L2 220 / 220	90°	<b>0973 997 031</b>	1
	200 x 50	2,35	220 / 220	90°	<b>0973 997 032</b>	1
	260 x 100	3,56	220 / 220	90°	<b>0973 997 033</b>	1
	400 x 120	5,06	220 / 220	90°	<b>0973 997 034</b>	1
<b>Connection rail</b> 	60 x 5	0,5	1.000	-	<b>0973 997 066</b>	1
<b>Angle, coated</b> 	50 x 30	0,5	1.000	-	<b>0973 997 065</b>	1
<b>Cable outlet</b> 	50 x 50	0,27	-	-	<b>0973 997 061</b>	1
<b>End cap</b> 	80 x 50	0,065	30	-	<b>0973 997 071</b>	1
	200 x 50	0,165	30	-	<b>0973 997 072</b>	1
	260 x 100	0,3	30	-	<b>0973 997 073</b>	1
	400 x 120	0,55	30	-	<b>0973 997 074</b>	1
<b>Special parts can be ordered via S Purchasing using the separate order form!</b>						
<b>Blind Rivet</b>	3.2 x 6.5				<b>0935 32 6</b>	500
<b>Galvanized sheet metal screw</b>	4.2 x 9.5				<b>0115 104 295</b>	500
<b>Mounting kit</b>	Plastic bag, approval and 2 marking signs				<b>0973 997 069</b>	1

# KB FIRE PROTECTION BANDAGE

66



Cable bandage that foams up in the event of a fire to prevent the fire from spreading via cables, cable bundles and cable conduits.

gray outside – white inside



## General construction permit/test reports

System approval,  
fire protection bandage KB  
Z.56.217-3549

### 1. Area of use

- To be installed in the system **E3** – KB fire protection bandage **E3**
- Fire protection jacket for preventing

fire from occurring and to prevent fire from spreading via cables and cable systems.

- The permissibility of application on cables and cable systems along rescue routes is to be decided upon in individual cases by the respective building supervisory board, e.g. in conjunction with the fire protection concept.

### 2. Properties

- Snug-fitting installation or installation running along profile.
- No special suspension devices required.
- Short installation time.
- Simple installation even in hard-to-reach places.
- Easy retrofitting.
- Dust-free installation.

### Technical data

- The fire protection fabric consists of a glass filament fabric and complies with Construction Material Class DIN 4102-B 1.

- The KB fire protection bandage is equipped on the **white inside** with the fire protection coating which foams up in the event of a fire.
- The **gray outside** of the carrier fabric is provided with a PU coating and can be subjected to damp cleaning without impairing the fire protection characteristics.
- The fire protection fabric may not be subject to weathering outdoors or to heavy moisture.
- It is installed with overlapping of  $\geq 5$  cm at the lengthwise and crosswise joints.
- At least every 50 cm, the bandage is secured with the universal tensioning strap and a suitable turnbuckle or wire, and can therefore be opened at any time for retrofitting.
- Thanks to the thin-walled bandage and the lengthwise and crosswise joints of the bandage only formed by overlapping, most of the heat which results from operating the cables can dissipate. Refer to the installation instructions and the general construction permit for the exact installation tasks.

### Note on applicationLAR

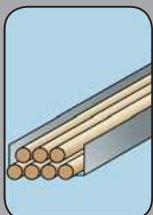

Install cable conduit.

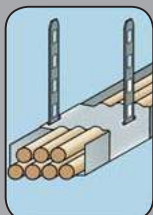

Load suspension devices and support structures with adapted cut-to-size sections.

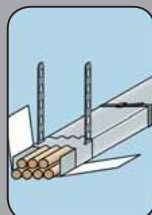

Wrap KB fire protection bandage Wrap around the 50 mm overlap on all sides.

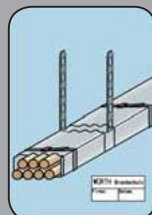

Secure with tensioning strap every 50 cm. Affix ID plate.

## KB FIRE PROTECTION BANDAGE

66

Ordering data				
Designation	color	Package format/Contents	Art. No.	P. Qty.
KB Fire Protection Bandage	gray/white	20 m roll/width 1,10 m, 22 m <sup>2</sup>	<b>0893 304 603</b>	1
Mounting kit		Plastic bag, approval, installation instructions, 2 ID plates	<b>0893 304 604</b>	1
Universal tensioning strap	Silver	5 m A2	<b>0547 000 10</b>	1
Turnbuckle	Silver	A2	<b>0547 000 11</b>	25
Winding Wire, 0.8 mm	Silver	25 pieces	<b>0874 111 100</b>	25

# 67 Intumescent Strip plus



grey

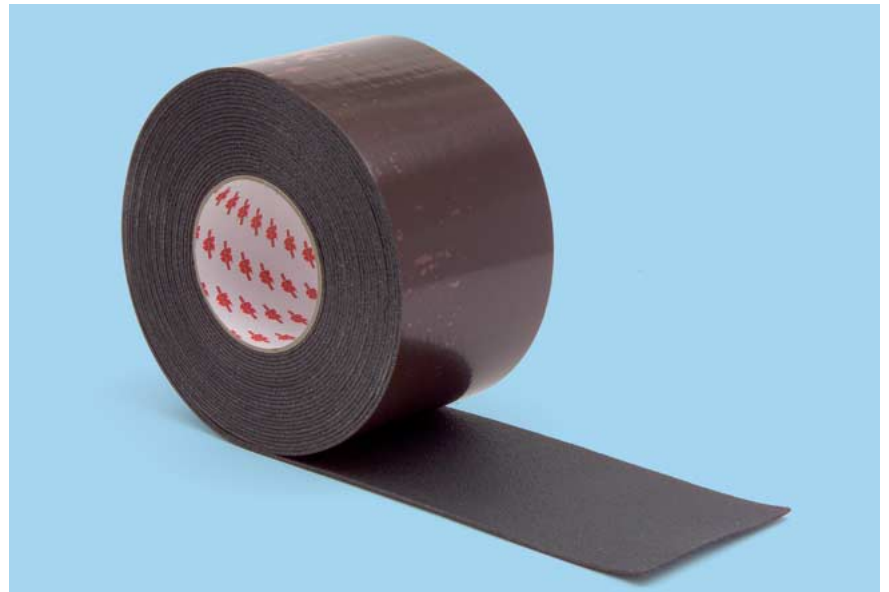

## General construction permit/test reports

Wall and ceiling ducts R 90  
in solid components  
and in light partition walls  
P-3333/2736-MPA BS

### 1. Application

- For use in the system: **H3**  
- Pipe Partition Intumescent Strip plus **H3**
- Fire-resistance rating R 30 – R 90 pursuant to DIN 4102 Part 11.
- For wall and ceiling ducts of non-flammable pipes provided with flammable or non-flammable insulation, e.g. with cold piping insulated with cold rubber.
- Material is laid around the insulation with a thickness of 1.5 mm (at least one layer; for larger pipe diameters, pursuant to construction-supervision test certificate P-3333/2736-MPA BS: several layers) and fixed in place with a self-adhesive coating.

### 2. Properties

- The spacing of the wound insulation may be 0 mm.
- Foams in case of fire.
- Easy to install.
- Does not drip in case of fire.
- No material exchange in fire areas.
- Very little space requirement.
- Easy to attach.

## Dimensions

Fire-resistance rating	R 90	R 30
Wall thickness of concrete/masonry	≥ 150 mm	-
Concrete ceiling thickness	≥ 150 mm	-
Wall thickness of light partition wall	≥ 100 mm	≥ 75 mm

Material	Maximum pipe diameter	
	Solid walls and ceilings	Light partition walls
Steel and cast iron	≤ 326,0 mm	≤ 204,0 mm
Stainless steel	≤ 204,0 mm	≤ 204,0 mm
Copper	≤ 88,9 mm	≤ 88,9 mm

It is essential to refer to the general construction test certificate for the materials, pipe outside diameters, pipe wall thicknesses and insulation thicknesses.

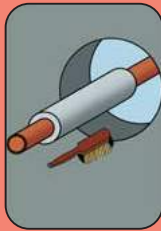
**Procedure for use**

Cleaning the opening.

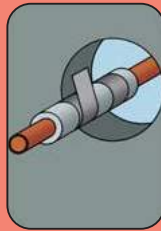

Lay intumescent strip plus around insulation according to approval (2x/1x).

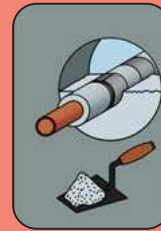

Close off remaining opening without leaving any hollow spaces with fire-retardant cement.

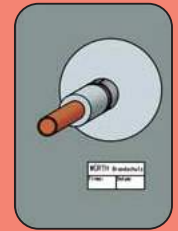

Apply identification plate.

**Ordering Information**

Designation	Thickness	Roll width	Roll length	Art. No.	P. Qty.
<b>Intumescent Strip plus</b>	1.5 mm	100 mm	10 m	<b>0893 304 520</b>	1
<b>Installation set</b>	Polyethylene bag, approval, installation instructions, 2 marking plates			<b>0893 304 530</b>	1

68

# Intumescent Strip



self-adhesive

Intumescent Strip  
self-adhesive

Installation set

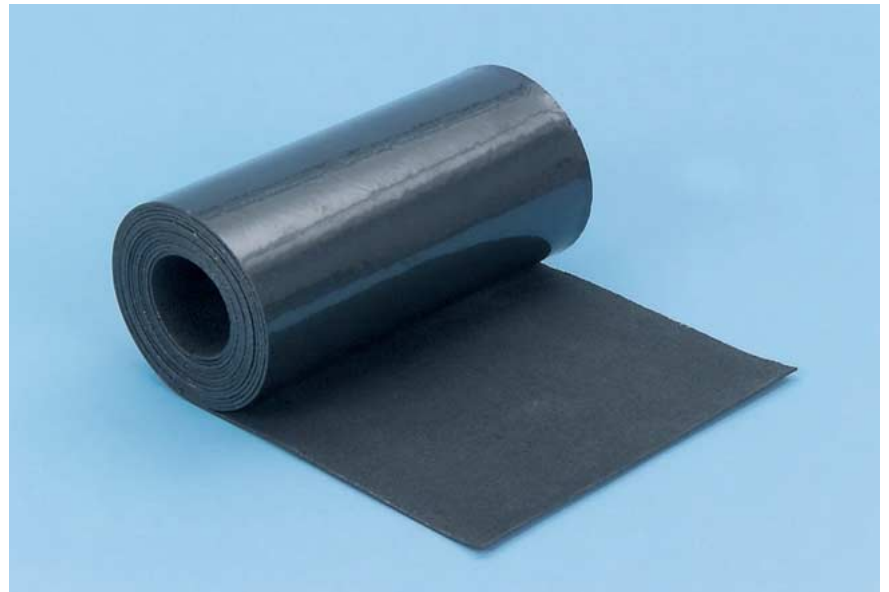

## General Construction Permit/Test Reports

General  
Construction  
Permit  
Z-19.11-1438

Technical Report  
on  
Noise Protection  
Measurement

### 1. Application

- For use in system **D1** + **G1**
  - Fire resisting foam 90 **D1**
  - Intumescent pipe partition **G1**
- For wall and ceiling ducts in accordance with LAR (Regulation for Line Systems).
- For non-flammable pipes up to 160 mm outside dia. and for flammable pipes up to 32 mm.
- For solid walls and solid ceilings from a thickness of 80 mm and for light partition walls from a thickness of 80 mm.

### 2. Advantages

- Can be used regardless of pipe diameter, as roll goods.
- Easy to install.
- Also suitable for cramped installation situations.
- Noise-decoupling effect.

### 3. Properties

- Material swells when exposed to fire, therefore meeting requirements according to LAR for pipe ducts.
- 2 mm thick.
- Dimensions: 155 mm x 5 m or 310 mm x 2.5 m.

### 4. Notes:

Cut intumescent strip in accordance with circumference of pipe. Glue self-adhesive strips around pipe in one layer. Should wall or ceiling be thicker than 15 cm, then a second strip must be laid around pipe so that the strip contacts the pipe over the complete ceiling or wall thickness. Pipe opening can now be filled with concrete or cement mortar. **The spacing of the individual lines are specified in the current Regulation for Line Systems (LAR).**

### Note on application

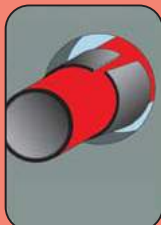

Adjust intumescent strip.



Pull off film and glue on pipe.

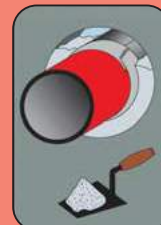

Close off remaining opening with fire-retardant cement.



Mount marking plate.

## Ordering Data

Designation	Thickness	Roll width	Roll length	Art. No.	P. Qty.
Intumescent Strip, self-adhesive	2 mm	155 mm	5 m	<b>0893 304 505</b>	1
		310 mm	2.5 m	<b>0893 304 506</b>	1
Installation Set	Polyethylene bag, approval, installation instructions, two ID plates			<b>0893 304 510</b>	1

68.1

# Intumescent Strip dB



Featuring sound-insulation properties, self-adhesive

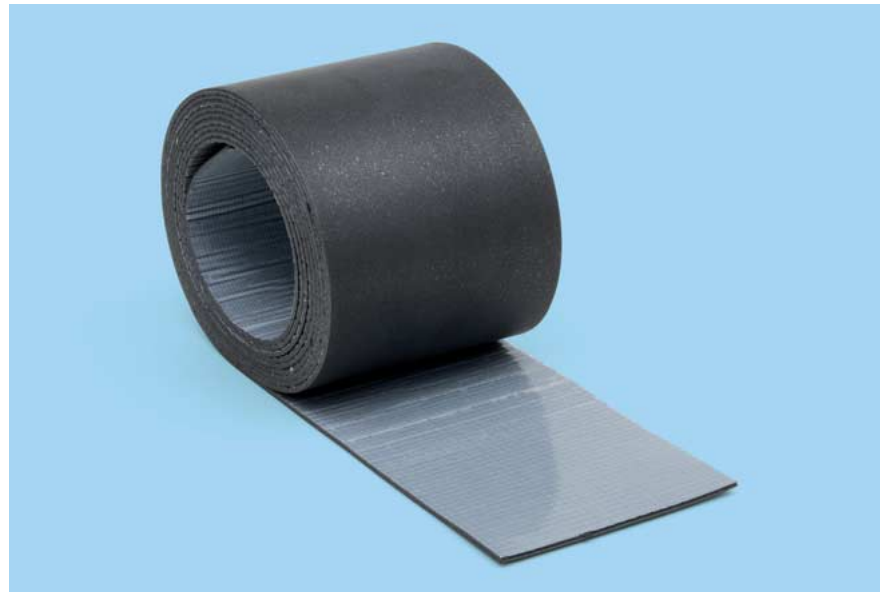

## General Construction Permit/Test Reports

Ceiling ducts  
R30 / R60 / R90  
P-3375/440/09-  
MPA BS

Sound test report  
P-BA 18/2009

### 1. Application

- For use in the system **G2**  
– intumescent pipe partition dB **G2**
- For ceiling ducts in solid ceilings made of concrete or aerated concrete that are  $\geq 150$  mm.
- Fire-resistance rating R30, R60, R90 pursuant to DIN 4102, Part 11.
- For non-flammable pipes made of cast metal (SML)  $\leq$  DN 125.
- In solid ceilings made of concrete and aerated concrete that are  $\geq 150$  mm.
- Also suitable for buildings with stricter sound protection requirements pursuant to VDI Guideline 4100.

### 2. Advantages

- Easy to install.
- Transition from cast metal pipes to plastic pipes directly after the ceiling is possible.

- Insulation above the ceiling only with stone wool mats, insulation thickness  $\geq 30$  mm with  $\geq 40$  kg/m<sup>3</sup> room weight required.
- SML connectors can simply be wrapped in as well.
- Zero-spacing of the stone wool mats is possible.
- Products do not depend on pipe diameters.

### 3. Properties

- Absolutely maintenance-free.
- Intumescent strip dB is self-adhesive.
- Seals off fire and smoke.

### 4. Notes

- Insulation lengths of stone wool mats above the ceiling:  
up to pipe diameter DN 50  $\geq 10$  cm,  
up to pipe diameter DN 125  $\geq 30$  cm.
- Intumescent strip dB is always to be wrapped around the cast metal pipe to the full ceiling thickness.
- Please heed the other information of the mounting instructions and test results P-3375/440/09-MPA BS.

### Note on application

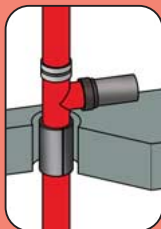

Cut intumescent strip dB to size and apply to the entire ceiling opening with the self-adhesive tape.

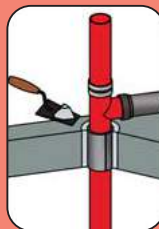

Close off the remaining opening with fire-retardant cement or fire-retardant mortar.

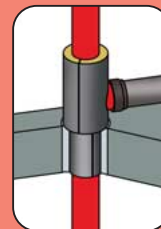

Apply flexen® stone wool mats of size 30 mm around the pipe at the appropriate height and secure with aluminum tape/winding wire.

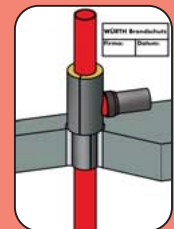

Affix ID plate.

### Ordering Data

Designation	Thickness	Roll width	Roll length	Art. No.	P. Qty.
<b>Intumescent Strip dB</b>	2 mm	155 mm	5 m	<b>0893 304 508</b>	1
<b>Installation Set</b>	Polyethylene bag, approval, installation instructions, two ID plates			<b>0893 304 509</b>	1

# 69 Intumescent Mat Plus



grey



## General building inspection approvals / test reports

Wall and ceiling lead-throughs R 90 in solid building parts P-3680/8053-MPA BS	Wall lead-throughs R 30-R 90 for light dividing walls P-3682/8073-MPA BS	Product certification Intumescent mat Plus Z-19.11-1569
---	---	--

### 1. Area of application

- For use in system **C** + **H2**
  - Fire partition W combi **C**
  - Pipe insulating intumescent mat Plus **H2**
- Fire resistance classification R 30 – R 90 according to DIN 4102.
- For wall and ceiling lead-throughs of non-flammable pipes equipped with inflammable insulation, for example, refrigeration pipes insulated with cold-resistant rubber.

- The material, with a thickness of 1.1 mm, is wrapped around the insulation in 2 layers and fixed in place with steel wire (at least 0.8 mm).
- In case of mineral wool or foam glass, one layer is sufficient.

### 2. Characteristics

- 0 mm space between insulations is possible.
- Foaming in case of fire.
- Easy to install or retrofit.
- Non-dripping in case of fire.
- No material change at fire barriers.

## Dimensions

Fire resistance classification	R 90	
Wall thickness concrete and masonry	≥ 150 mm	
Ceiling thickness	≥ 150 mm	
Wall thickness light dividing walls	for F 30 ≥ 75 mm at F 90 ≥ 100 mm	
Max. pipe diameter steel, stainless steel, cast iron	≤ 326.0 mm	insulation thickness 6 - 100 mm
Light dividing walls, steel and cast iron pipes	≤ 219.1 mm	insulation thickness 9 - 100 mm
Light dividing walls, stainless steel pipes	≤ 204.0 mm	insulation thickness 9 - 100 mm
Max. pipe diameter for copper	≤ 88.9 mm	insulation thickness 9 - 100 mm

For materials, outside pipe diameters, pipe wall thicknesses and insulation thicknesses, please refer to the general building inspection test certificates.

## Instructions for use

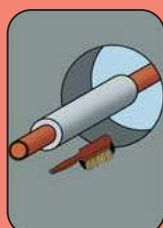

Clean the opening.

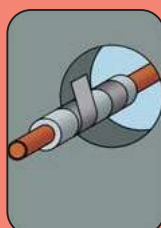

Wrap the Intumescent Mat Plus around insulation in accordance with approval (2 layers, 1 layer).

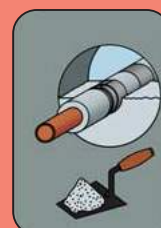

Fill the remaining opening with fire protection cement



Secure protruding mat with 0.8 mm wire, affix identification label.

### Ordering Specifications

Designation	Thickness	Width of roll	Length of roll	Art. No.	Pack Qty.
<b>Intumescent mat Plus</b>	1.1 mm	125 mm	10 m	<b>0893 304 521</b>	1
	1.1 mm	150 mm	10 m	<b>0893 304 522</b>	1
	1.1 mm	250 mm	10 m	<b>0893 304 523</b>	1
<b>Installation set</b>	Poly bag, certificate, installation instructions, 2 identification labels			<b>0893 304 529</b>	1
<b>Binding wire</b>	0.8 mm	soft galvanized, roll à 100 g		<b>0874 111 100</b>	25

### Way of installation

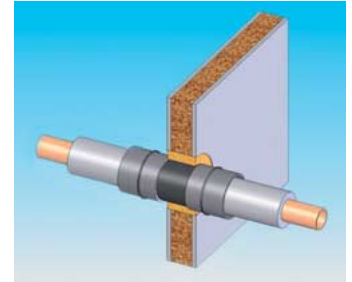
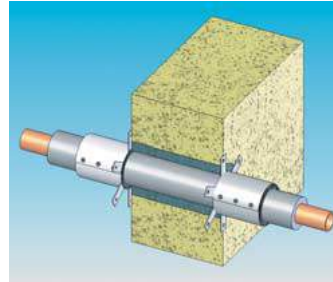
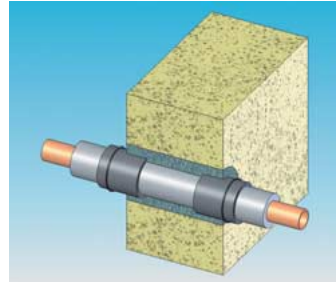
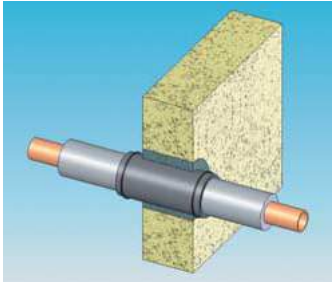

# WEDGES FOR SUBSEQUENT INSTALLATION

71



**Length** 300 mm  
**Height** 25/75 mm



## General construction permit/test reports

System approval,  
combination partition  
system **M**  
Z-19.15-1333

System approval,  
fire partition M  
system **W**  
S120  
Z-19.15-812

### 1. Area of use

- For use in the system + **M** **W**
  - Combination partition **M**
  - Fire partition M **W**
- For pre-planned subsequent installation of cables in the wall and ceiling partition system.
- For installation in fresh fire-protection mortar.

### 2. Advantages

- Subsequent removal possible via light hammer blows.
- Cables can be installed subsequently with ease through the space opened in this way.

### 3. Properties

- Wedge-shaped fitted element made of non-flammable fiber-silicate boards.

### Note on processing



Clean the opening and pre-wet the reveal of the structure.



Mixing the fireproof mortar.



Installing the fireproof mortar: Shutter larger ducts on one side.



Installation of wedges for subsequent installation for later installation.



Affix the ID plate.



For subsequent installation: Remove the wedges for subsequent installation with gentle hammer strikes.

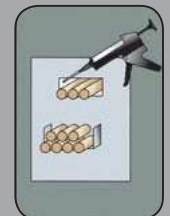

Subsequent installation of cables: Re-seal the remaining opening.

### Ordering data

Designation	Package format/Contents	Dimensions	Art. No.	P. Qty.
Wedge for Subsequent Installation	16 pieces (8 pairs)	Length: 300 mm Height: 25/75 mm	<b>0893 302 100</b>	16

**MARKING PLATES**
**72**

**FIRE PARTITION**
**for cables and electrical lines**

System A	Combination partition	S 90	Z-19.15-1333
System B	Fire partition M	S 120	Z-19.15-812
System C	Fire partition W combination	S 90	Z-19.15-1413
System E	Fire-protection cushion 90	S 90	Z-19.15-1117

Partition manufacturer:	Date:	Partition No.
-------------------------	-------	---------------

This partition may not be damaged! Damage is to be reported to the manufacturer and must be properly repaired!

MWF - A00027 - 04/10 - 0893 310 001 - ©
**Ordering information**

Designation	Dimensions	Art. No.	P. Qty.
Marking plates	Length: 140 mm Height: 80 mm	<b>0893 310 001</b>	20

**FIRE PARTITION**
**for pipelines and joints**

System F	Pipe partition M	R 90	Z-19.17-1374
System G	Pipe partition E	according to LAR in	
System G1	Intumescent pipe partition	F 90 components	Z-19.11-1116/1438
System H	Pipe partition Z	R 90	P-3933/2404-MPA BS
System H1	Pipe partition KL	R 30 - R 120	P-MPA-E01-037
System I	Joint system K	F 30 - F120	011479-Th
System J	Joint system E	F 90	P-3260/5499-MPA BS
System L	Joint system P	F 30 - F 120	P-3568/2560-MPA BS

Partition manufacturer:	Date:	Partition No.
-------------------------	-------	---------------

This partition may not be damaged! Damage is to be reported to the manufacturer and must be properly repaired!

MWF - A00027 - 04/10 - 0893 310 002 - ©
**Ordering information**

Designation	Dimensions	Art. No.	P. Qty.
Marking plates	Length: 140 mm Height: 80 mm	<b>0893 310 002</b>	20

## MARKING PLATES

72



### FIRE PARTITION for cables and pipes

System A	Combination partition	S 90	Z-19.15-1333
System B1	Short cable box	S 30/S 90	Z-19.15-1428
System B1	Long cable box	S 90	Z-19.15-1429
System C	Fire partition W combination	S 90	Z-19.15-1413
System C1	Fire partition W 1	S 90	Z-19.15-1493
System D1	Fire resisting foam 90	S 90/R 90	Z-19.15-1472 / Z-19.17-1773
System D2	Intumescent cable partition	S 90	Z-19.15-1483
System E1	Fire protection stones	S 90	Z-19.15-1494
System E1	Fire protection plugs	S 90	Z-19.15-1495
System F	Pipe partition M	R 90	Z-19.17-1374

Partition manufacturer:	Date:	Partition No.
-------------------------	-------	---------------

This partition may not be damaged! Damage is to be reported to the manufacturer and must be properly repaired!

MWF - A00027 - 04/10 - 0893 310 003 - ©

#### Ordering information

Designation	Dimensions	Art. No.	P. Qty.
Marking plates	Length: 140 mm Height: 80 mm	<b>0893 310 003</b>	20



### FIRE PARTITION for cables and pipes

System D3	2-C intumescent fire resisting foam	S 90	Z-19.15-1722
	2-C intumescent fire resisting foam	R 90	P-3167/6595-MPA BS
	Cable coating		U-03 119
System F2	Pipe partition M light	R 90	Z-19.17-1679
System F3	Pipe partition I plus / I iso	R 90	Z-19.17-1673 / Z-19.17-1922
System H2	Pipe partition IM-M	R 90	P-3680/8053-MPA BS
	Pipe partition IM-LT	R 90	P-3682/8073-MPA BS
System H3	Pipe partition intumescent strip plus	R 30/90	P-3333/2736-MPA BS

Partition manufacturer:	Date:	Partition No.
-------------------------	-------	---------------

This partition may not be damaged! Damage is to be reported to the manufacturer and must be properly repaired!

MWF - A00027 - 05/10 - 0893 310 004 - ©

#### Ordering information

Designation	Dimensions	Art. No.	P. Qty.
Marking plates	Length: 140 mm Height: 80 mm	<b>0893 310 004</b>	20

## ID PLATES

72



### BRANDABSCHOTTUNG

für Kabel bzw. Rohre

System E3	Brandschutzbandage KB für Kabel und Kabeltrassen	siehe Zulassung	Z-56.217-3549
System E4	Brandschutzkanal	I30/I60/I90/I120	P-MPA-E-09-011
System G2	Rohrabschottung dB intumeszierend	R30/R60/R90	P-3375/440/09-MPA BS
System W1	Installationsschacht IBS 90	I90	P-MPA-E-06-025
System W2	Installationsschacht I-Block 90®	I90	P-MPA-E-06-025

Hersteller der Abschottung:	Datum:	Schott-Nr.
-----------------------------	--------	------------

Dieses Schott darf nicht beschädigt werden! Beschädigungen sind dem Hersteller zu melden und müssen wieder fachgerecht ausgebessert werden!

MWC - A00027 - 04/12 - 0893 310 005 - ©

#### Ordering data

Designation	Dimensions	Art. No.	P. Qty.
ID plates	Length 140 mm Height: 80 mm	<b>0893 310 005</b>	20

# 81 Elastic Joint-Sealing Tape



Highly flexible joint-sealing system made of fire-resistant, waterproof polyurethane foam.



## General construction permit / test reports

Material test certificate: P-ift-261 2 8579	General construction test certificate <b>IBMB</b> MPA Braunschweig P-3568/2560-MPABS
--	---

### 1. Application

- For use in system **L**  
– Joint system P
- For expansion joints in walls, ceilings and connecting areas.

### 2. Advantages

- Quick and clean application.
- Easy application; no special tools required.
- Very good noise and heat insulation.
- Fire resistance time up to F 120.
- No joint fracturing.
- No pre-moistening necessary.

### 3. Properties

- Pre-compressed tapes for quick and easy application.
- Intumescent self-adhesive application aid included.
- Material class DIN 4102 - B1.
- Room weight approx. 170 kg/m<sup>3</sup>.
- Seals off fire and smoke.
- UV and water resistant.
- Compatible with silicone and acrylate sealing compounds.
- The joint-sealing tape contains no silicone.

### Notes on application



Clean application surface.



Measure joint and cut tape to proper size.

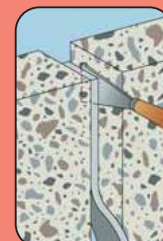
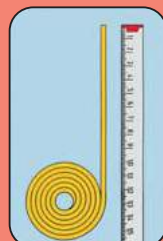

Pull off cover paper and affix tape in the joint.



Optional: Wipe with sealing compound after expansion of the tape.

## Dimensions

Joint width from ... to ... mm	Fire resistance time	Minimum wall/ ceiling thickness in mm	Dimensions in mm
7 – 10	F 30	100	7 / 25 x 50
7 – 10	F 120	150	7 / 25 x 80
10 – 14	F 30	100	10 / 35 x 50
10 – 14	F 120	150	10 / 35 x 80
12 – 20	F 30	100	12 / 45 x 50
12 – 20	F 120	150	12 / 45 x 80
18 – 28	F 30	100	18 / 70 x 50
18 – 28	F 120	150	18 / 70 x 100
22 – 45	F 30	100	22 / 90 x 50
22 – 45	F 120	150	22 / 90 x 100

## Technical data

<b>Raw material base</b>	fire-resistant, waterproof polyurethane foam
<b>Colour</b>	anthracite
<b>Room weight</b>	approx. 170 kg/m <sup>3</sup>
<b>Max. storage time</b>	1 year
<b>Temperature range</b>	-40 °C to +120 °C
<b>Resistant to</b>	UV, water
<b>Elasticity</b>	20% of joint width
<b>Compression set</b>	< 10%

### General construction test certificate

#### Variations of elastic joint-sealing tape

All variations are acceptable for ceiling joints, wall joints and wall-connection joints

All variations achieve F30 or F120, depending on the installation depth

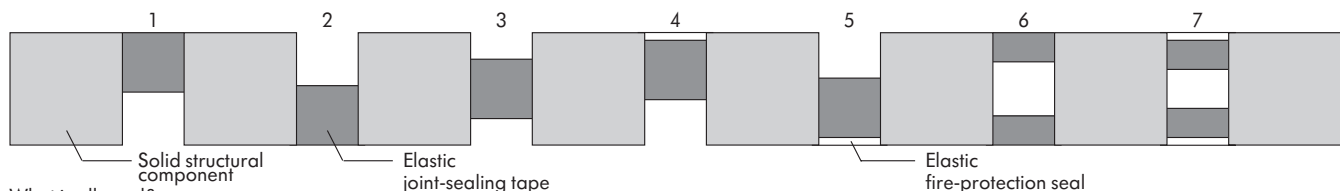

What is allowed?

- Flush installation with no silicone cover (Nos. 1, 2 and 6)
- Centred installation (No. 3)
- Flush installation with silicone cover (Nos. 4, 5 and 7)
- Asymmetrical installation (No. 6)

The total installation depth for a joint size is always the same.  
Example: For F120, an installation depth of 80 mm is required, but two x 40 mm are also permissible. The position of the tape/tapes is irrelevant.

## Ordering information

Designation Dimensions in mm	Colour	Package format/ Contents		Art. No.	Carton / Qty.
		Roll / m	Carton / m		
7 / 25 x 50	anthracite	6.0	48	<b>0875 961 040</b>	8
7 / 25 x 80	anthracite	6.0	30	<b>0875 961 080</b>	5
10 / 35 x 50	anthracite	4.5	36	<b>0875 961 450</b>	8
10 / 35 x 80	anthracite	4.5	22.5	<b>0875 961 480</b>	5
12 / 45 x 50	anthracite	4.0	32	<b>0875 962 050</b>	8
12 / 45 x 80	anthracite	4.0	20	<b>0875 962 080</b>	5
18 / 70 x 50	anthracite	2.6	20.8	<b>on request „S“</b>	8
18 / 70 x 100	anthracite	2.6	10.4		4
22 / 90 x 50	anthracite	2.1	16.8		8
22 / 90 x 100	anthracite	2.1	8.4		4

# METAL SPACING CLAMPS

Appendix  
1.1



**Cable spacing clamp with oblong hole**



**Screw spacing clamp with M6 thread**

## General construction permit/test reports

Function integrity class  
E30 and E90.

Standard laying systems  
per DIN 4102 Part 12.

Test report can be ordered by calling  
+49 (7940) 15-2408.

### Area of use:

- Laying of function integrity cables under the ceiling and horizontal or vertical wall laying.

### Advantages:

- Cable installation: Max. 3 cables per clamp.  
Diameter of the individual cable: Max. 25 mm.
- Quick cable laying without removal of the clamp screws.

### Features:

- Cable spacing clamp: Material: Galvanized steel.  
Screw spacing clamp: Material: Galvanized and yellow-passivated steel.

Cable spacing clamp with oblong hole		
Clamping range dia. in mm	Art. No.	P. Qty.
15 - 19	<b>0971 601 011</b>	50
19 - 24	<b>0971 601 016</b>	
24 - 29	<b>0971 601 021</b>	
29 - 38	<b>0971 601 029</b>	25
38 - 52	<b>0971 601 036</b>	
52 - 63	<b>0971 601 048</b>	

Storable in <sup>®</sup>ORSY

Screw spacing clamp with M6		
Clamping range dia. in mm	Art. No.	P. Qty.
5 - 6	<b>0971 601 206</b>	100
7 - 8	<b>0971 601 208</b>	
9 - 10	<b>0971 601 210</b>	
11 - 12	<b>0971 601 212</b>	
13 - 14	<b>0971 601 214</b>	
15 - 16	<b>0971 601 216</b>	
17 - 18	<b>0971 601 218</b>	
19 - 20	<b>0971 601 220</b>	
21 - 23	<b>0971 601 222</b>	
24 - 25	<b>0971 601 225</b>	
26 - 27	<b>0971 601 226</b>	50
28 - 29	<b>0971 601 228</b>	
31 - 32	<b>0971 601 232</b>	
34 - 35	<b>0971 601 235</b>	
39 - 40	<b>0971 601 240</b>	25
41 - 43	<b>0971 601 242</b>	
49 - 51	<b>0971 601 250</b>	
53 - 55	<b>0971 601 254</b>	25
61 - 63	<b>0971 601 263</b>	

Storable in <sup>®</sup>ORSY

# Annex 1.2 Cable Clamps



Type H  
Type AC

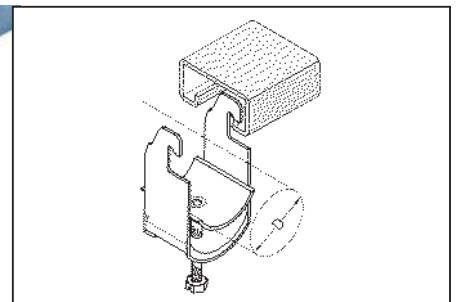
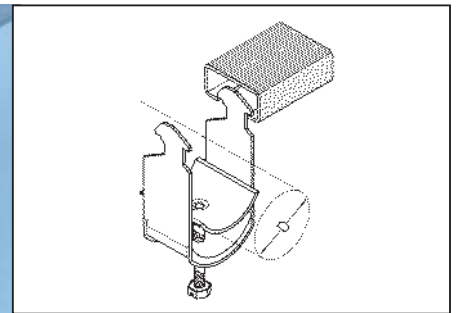

## General building code approval / test reports

Function preservation class  
E30 and E90.  
Standard installation systems  
according to DIN 4102 Part 12.



### Area of application:

1. Installation of function preservation cables under the ceiling, as well as horizontal or vertical on walls.
2. On all surfaces in connection with profile rail, Art. No. 0971 060 100 (Type H), or profile rail, Art. No. 0971 060 200 (Type AC), as well as corresponding Würth fireproof wall plug.

### Advantages:

1. Can be used with or without long cable trays (see test reports).
2. Capacity: max 3 cable per clamp, diameter of individual cables max 25 mm.

### Characteristics:

Material: steel, hot-galvanized.

Clamping range Ø mm	Type H Art. No.	Type AC Art. No.	Pack Qty.
8-12	<b>0971 008</b>	<b>0971 008 12</b>	100
12-16	<b>0971 012</b>	<b>0971 012 16</b>	
16-20	<b>0971 016</b>	<b>0971 016 20</b>	
20-24	<b>0971 020</b>	<b>0971 020 24</b>	
24-28	<b>0971 024</b>	<b>0971 024 28</b>	
28-32	<b>0971 028</b>	<b>0971 028 32</b>	
32-36	<b>0971 032</b>	<b>0971 032 36</b>	
36-40	<b>0971 036</b>	<b>0971 036 40</b>	
40-44	<b>0971 040</b>	<b>0971 040 44</b>	
44-48	<b>0971 044</b>	<b>0971 044 48</b>	
48-52	<b>0971 048</b>	<b>0971 048 52</b>	50
52-56	<b>0971 052</b>	<b>0971 052 56</b>	
56-60	<b>0971 056</b>	<b>0971 056 60</b>	

## CABLE TROUGH

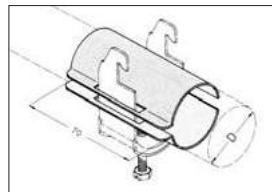

Anhang  
1.2



### Area of Application:

- Proper routing and installation of safety and fire-proof cables.
- The reduce surface pressure of particularly pressure-sensitive cables.
- Suitable for cable clamps Type H and AC.

### Attention:

Two cable troughs are required for each cable clamp!

Clamping Range Ø in mm	Art. No.	P. Qty.
8 - 12	<b>0971 008 123</b>	100
12 - 16	<b>0971 012 163</b>	100
16 - 20	<b>0971 016 203</b>	100
20 - 24	<b>0971 020 243</b>	100
24 - 28	<b>0971 024 283</b>	100
28 - 32	<b>0971 028 323</b>	100
32 - 36	<b>0971 032 363</b>	100

Clamping Range Ø in mm	Art. No.	P. Qty.
36 - 40	<b>0971 036 403</b>	100
40 - 44	<b>0971 040 443</b>	100
44 - 48	<b>0971 044 483</b>	100
48 - 52	<b>0971 048 523</b>	100
52 - 56	<b>0971 052 563</b>	100
56 - 60	<b>0971 056 603</b>	100

### Characteristics:

Material: steel, hot-galvanized.

## PROFILE RAILS

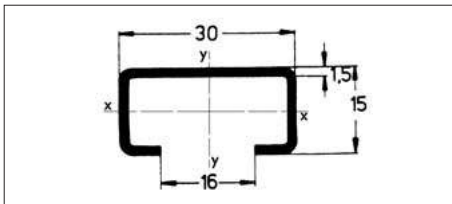

Dimensions mm	Art.-No.	P. Qty.
30 x 15 x 1.5	<b>0971 060 100</b>	8 (4 x 2 m)

### Static Values

Cross section A	1.02 cm <sup>2</sup>
Moment of inertia I <sub>x</sub>	0.32 cm <sup>4</sup>
Moment of inertia I <sub>y</sub>	1.36 cm <sup>4</sup>
Section modulus W <sub>x</sub>	0.35 cm <sup>3</sup>
Section modulus W <sub>y</sub>	0.90 cm <sup>3</sup>
Inertial radius i <sub>x</sub>	0.56 cm
Inertial radius i <sub>y</sub>	1.15 cm

### Carrying Capacity

Carrying capacity*	7.90 kN/m
Max. hook load**	2.00 kN

\* = in concrete B25 at a distance of 250 mm.

\*\* = at distance of 250 mm and mounting distance of 250 mm.

### with hole pattern, for cable clamps, Type H

- Euronorm EN 50024/C 30.
- Material: steel, sendzimir hot-galvanized (EN 10147, formerly DIN 17162).
- **Hole pattern:**  
**35 x 7 mm (longitudinal perforation).**

## PROFILE RAILS

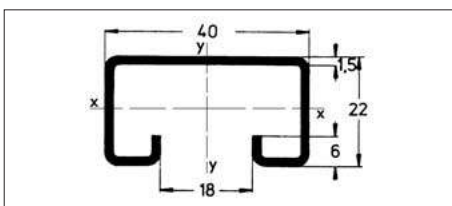

Dimensions mm	Art.-No.	P. Qty.
40 x 22 x 1.5	<b>0971 060 200</b>	8 (4 x 2 m)

### Static Values

Cross section A	1.55 cm <sup>2</sup>
Moment of inertia I <sub>x</sub>	1.08 cm <sup>4</sup>
Moment of inertia I <sub>y</sub>	3.39 cm <sup>4</sup>
Section modulus W <sub>x</sub>	0.89 cm <sup>3</sup>
Section modulus W <sub>y</sub>	1.70 cm <sup>3</sup>
Inertial radius i <sub>x</sub>	0.83 cm
Inertial radius i <sub>y</sub>	1.48 cm

### Carrying Capacity

Carrying capacity*	20,00 kN/m
Max. hook load**	5,00 kN

\* = in concrete B25 at a distance of 250 mm.

\*\* = at distance of 250 mm and mounting distance of 250 mm.

### with hole pattern, for cable clamps, Type AC

- Euronorm EN 60715/C 40.
- Material: steel, sendzimir hot-galvanized (EN 10147, formerly DIN 17162).
- **Hole pattern:**  
**30 x 11 mm (longitud. perforation).**

## CABLE BRANCH BOXES WBK

Appendix  
1.3



### General building inspection approvals / test reports

Function preservation class  
E30 and E90.

Obtain general building inspection  
approval certificate by calling  
Tel. +49/7940/15-2408.

#### Area of application:

- Through or branch box.

#### Advantages:

- Left-over cable lengths can be connected/used.
- No additional fire protection covers required.

#### Characteristics:

Type of protection: IP54.

Material: Duroplast, halogen and silicone free.

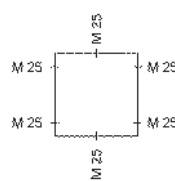
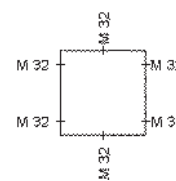
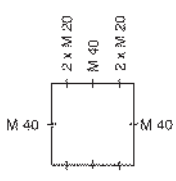
Type	<b>WBK 2 (5 x 6.0 mm<sup>2</sup>)</b> <b>U<sub>i</sub> = 450 V</b>	<b>WBK 3 (5 x 10.0 mm<sup>2</sup>)</b> <b>U<sub>i</sub> = 450 V</b>	<b>WBK 4 (5 x 16.0 mm<sup>2</sup>)</b> <b>U<sub>i</sub> = 450 V</b>
Dimensions	100 x 100 x 50 mm	115 x 115 x 66 mm	165 x 165 x 76 mm
Area of use	Through box 0.5 to 6.0 mm <sup>2</sup> and branch box 0.5 to 1.5 mm <sup>2</sup>	Through box 1.0 to 10.0 mm <sup>2</sup> and branch box 1.0 to 4.0 mm <sup>2</sup>	Through box 1.5 to 16.0 mm <sup>2</sup> and branch box 1.5 to 4.0 mm <sup>2</sup>
Dimensioned drawing	 <p>1 sealing plug and 4 external muffs M25, sealing range 9 - 18.5 mm</p>	 <p>1 sealing plug and 4 external muffs M32, sealing range 13 - 23 mm</p>	 <p>1 sealing plug and 4 external muffs M40, sealing range 17 - 30 mm</p>
<b>Art.-No.</b>	<b>0975 050 020</b>	<b>0975 050 030</b>	<b>0975 050 040</b>
<b>Pack Qty.</b>	1	1	1

Appendix  
**1.4**



# Strong Hold in Case of Fire!

Fire resistance duration of selected plugs.

Tested according to the uniform temperature curve 1.200°C (ISO 834, DIN 4102 T. 2) in cracked concrete B 25 (zone subject to tensile forces).

Securing element Specification No.	Product designation	Dim.	Maximum load (kN) for				Permit number	Test report number			
			F30	F60	F90	F120					
<b>02.1</b>	<b>Screw anchor</b>	<b>W-SA</b>	10 mm <sup>dia. 1)</sup> 12 mm <sup>dia. 1)</sup>	2.70 4.40	2.00 3.20	1.50 2.40	1.00 1.50	ETA-05/0012	3232/2228		
	<b>Screw anchor</b>	<b>W-SA A4</b>	10 mm <sup>dia. 1)</sup> 12 mm <sup>dia. 1)</sup>	2.70 4.40	2.00 3.20	1.50 2.40	1.00 1.50	ETA-05/0011	3815/0592		
<b>02.5</b>	<b>Fixing anchor</b>	<b>W-FAZ/S</b>	M 8	1.90	0.90	0.60	0.40	ETA-03/0018 Option 1	3152/0906-4		
			M 10	4.00	2.20	1.30	0.80				
			M 12	5.50	3.50	2.00	1.20				
			M 16	9.00	6.00	4.00	3.00				
<b>02.6</b>	<b>Fixing anchor</b>	<b>W-FAZ/A4</b>	M 8	9.00	5.00	1.80	1.00	ETA-99/0011 Option 1	3152/0906-4		
			M 10	15.00	9.00	4.00	2.00				
			M 12	19.00	12.00	5.00	3.00				
			M 16	30.00	15.00	7.50	6.00				
	<b>Fixing anchor</b>	<b>W-FAZ/HCR</b>	M 8	9.00	5.00	1.80	1.00	ETA-04/0070 Option 1	3152/0906-4		
			M 10	15.00	9.00	4.00	2.00				
			M 12	19.00	12.00	5.00	3.00				
			M 16	30.00	15.00	7.50	6.00				
	<b>Fixing anchor</b> Fire loading as per „ZTV-Tunnel“	<b>W-FAZ/HCR</b>	M 8 M 10 M 12 M 16	max. loading as per German Standard „ZTV Tunnel“ 1.00 1.90 3.00 5.50				ETA-04/0070 Option 1	3152/0906-4		
<b>03</b>	<b>High-performance anchor</b>	<b>W-HAZ</b>	M 6	1.80	0.85	0.55	0.40	ETA-02/0031 Option 1	3254/0301-3		
			M 8	2.60	1.40	0.95	0.75				
			M 10	7.00	2.90	1.75	1.20				
			M 12	10.00	4.10	2.50	1.70				
			M 16	16.00	6.90	4.25	3.00				
			M 20	22.00	10.00	6.30	4.50				
<b>06</b>	<b>Gas concrete anchor</b>	<b>W-PA, Type A</b>	M 6	–	–	0.35 <sup>2)</sup>	0.30 <sup>2)</sup>	Z-21.1-1525	–		
			M 8	–	–	0.45 <sup>2)</sup>	0.35 <sup>2)</sup>				
			M 10	–	–	0.80 <sup>2)</sup>	0.75 <sup>2)</sup>				
	<b>Gas concrete anchor</b>	<b>W-PA, Type I</b>	M 6	–	–	0.35 <sup>2)</sup>	0.30 <sup>2)</sup>				
			M 8	–	–	0.45 <sup>2)</sup>	0.35 <sup>2)</sup>				
			M 10	–	–	0.80 <sup>2)</sup>	0.75 <sup>2)</sup>				
<b>11.1</b>	<b>Fixing anchor</b>	<b>W-FA/S</b>	M 6	0.90	0.50	0.30	0.25	ETA-02/0001 Option 7 <sup>3)</sup> ETA-05/0019 <sup>3)</sup> Z-21.1-1614 <sup>3)</sup>	3006/0057-1		
			M 8	1.40	0.80	0.50	0.40				
			M 10	2.20	1.20	0.80	0.60				
	<b>Fixing anchor</b>	<b>W-FA/S-LG</b>	M 12	3.20	1.80	1.20	0.90				
			<b>W-FA</b>	Galvanized steel	M 16	6.00	3.40			2.20	1.70
					M 6	0.90	0.50			0.30	0.25
M 8	2.30	1.70			1.40	1.30					
<b>11.2</b>	<b>Fixing anchor</b>	<b>W-FA/A4</b>	M 10	3.60	2.60	2.20	2.00				
			M 12	5.20	3.80	3.20	2.90				
			M 16	9.70	7.00	6.00	5.40				
			<b>Fixing anchor</b>	<b>W-FA/HCR</b>	M 6	max. loading as per „ZTV-Tunnel“ 0.25					
<b>13.1</b>	<b>Pound-in plug</b>	<b>W-ED/S</b>	M 6	1.70	0.70	0.40	0.30	ETA-02/0044 ETA-05/0120 ETA-03/0051 Option 7 <sup>3)</sup> Z-21.1-1609 <sup>3)</sup> ETA-05/121	3006/0057-2		
			M 8x30	1.70	0.70	0.40	0.30				
			M 8x40	3.00	1.50	0.80	0.60				
			M 10	4.70	2.40	1.30	1.00				
			M 12	6.90	3.50	1.80	1.40				
			<b>Pound-in plug</b>	<b>W-ED</b>	M 6	1.70	0.70			0.40	0.30
	M 8x30	1.70			0.70	0.40	0.30				
	M 8x40	3.00			1.50	0.80	0.60				
	M 10	4.70			2.40	1.30	1.00				
	M 12	6.90			3.50	1.80	1.40				
	<b>13.1</b>	<b>Pound-in plug</b>			<b>W-ED/A4</b>	M 6	1.70			0.70	0.40
			M 8x30	1.70		0.70	0.40			0.30	
M 8x40			3.00	1.50		0.80	0.60				
M 10			4.70	2.40		1.30	1.00				
M 12			6.90	3.50		1.80	1.40				
<b>13.1</b>			<b>Screw anchor</b>	<b>W-SA</b>		5 mm <sup>dia. 1)</sup>	0.50	0.30	0.25	0.10	Z-21.1-1597
	6 mm <sup>dia. 1)</sup>	0.90			0.60	0.40	0.30				
	7.5 mm <sup>dia. 1)</sup>	1.50			1.10	0.80	0.50				

Securing element Specification No. Product designation			Dim.	Maximum load (kN) for				Permit number	Test report number
				F30	F60	F90	F120		
<b>21</b>	<b>Shear connector</b>	<b>W-VAD</b>	M 8	2.00	1.00	0.50	0.40	Z-21.3-1514 Z-21.3-1752	3152/0906-2
			M 10	3.50	1.80	1.30	1.00		
			M 12	5.00	2.80	2.00	1.50		
			M 14	5.00	2.80	2.00	1.50		
			M 16	7.00	3.75	2.50	2.00		
<b>23.1</b>	<b>Injection system with anchor rod VZ</b>	<b>W-VIZ/S</b>	M 8	3.00	0.30	–	–	ETA-04/0094	3714/0105
			M 10	7.00	0.95	0.30	–		
			M 12	10.00	2.80	1.35	0.80		
			M 16	12.00	6.40	4.40	3.40		
			M 20	17.00	8.80	6.00	4.50		
			M 24	24.50	12.70	8.60	6.50		
<b>23.2</b>	<b>Injection system with anchor rod, stainless steel A4</b>	<b>W-VIZ/A4</b>	M 8	3.00	0.30	–	–	ETA-04/0095	3714/0105
			M 10	7.00	0.95	0.30	–		
			M 12	10.00	2.80	1.35	0.80		
			M 16	12.00	6.40	4.40	3.40		
			M 20	17.00	8.80	6.00	4.50		
			M 24	24.50	12.70	8.60	6.50		
<b>23.5</b>	<b>Injection system with anchor rod, galvanised steel</b>	<b>WIT-C100</b>	M 8	1.5	0.9	0.3	–	–	3434/4348-1
			M 10	1.5	1.1	0.7	0.3		
	<b>Injection system with anchor rod, stainless steel A4</b>	<b>WIT-C200</b>	M 8	1.5	0.9	0.3	–		3434/4348-1
			M 10	1.5	1.1	0.7	0.3		
<b>24</b>	<b>Injection system with anchor rod, galvanised steel</b>	<b>WIT-C200</b>	M 8	0.90	0.35	0.20	0.15	Z-21.3-1671	3254/0301-2
			M 10	0.90	0.35	0.20	0.15		
			M 12	0.90	0.35	0.20	0.15		
	<b>Injection system with anchor rod, stainless steel A4</b>	<b>WIT-C200</b>	M 8	0.90	0.35	0.20	0.15		
			M 10	0.90	0.35	0.20	0.15		
			M 12	0.90	0.35	0.20	0.15		
<b>32</b>	<b>Quick-action anchor</b>	<b>W-ZS</b>	Ø 6	0.45	0.30	0.20	0.15	Z-21.1-1028	3711/3665-4
<b>33</b>	<b>Ceiling nail</b>	<b>W-DN</b>	Ø 6	–	0.40 <sup>2)</sup>	0.25 <sup>2)</sup>	–	Z-21.1-1506	
<b>34</b>	<b>Impact plug W-SD</b>	<b>Type W-DM</b>	Ø 6	0.35	0.35	0.35	–	Z21.1-917 <sup>2)</sup>	–
		<b>Type WMu LF8</b>	Ø 6	0.22	0.22	0.22	–		
		<b>Type WDM/L</b>	Ø 6	0.35	0.35	0.35	–		
		<b>Type WMu/F10</b>	Ø 6	0.35	0.35	0.35	–		
		<b>Type W 6 L 8 x...</b>	Ø 6	0.35	0.35	0.35	–		

<sup>1)</sup> Values dependent on the setting depth.

The exact minimum setting depth is contained in the corresponding fire-protection test report.

<sup>2)</sup> The corresponding sections in the permit must be observed.

<sup>3)</sup> Observe the permit according to the application case, plug dimension and plug material.

When using according to the general construction permit, the edge distances, axial distances and minimum component thicknesses listed in the permit must be complied with. The respective smaller value between the load in the permit and the load listed here must be assumed. The installation instructions of the individual securing elements and the anchoring depths specified in the test report must always be complied with. All specifications without guarantee. As at 01/06.

**Additional anchor and plug systems can be found in the Würth Plug Technology Folder in the Plug Products Specification or on the Internet at: [www.wuerth.de/duebeltechnik](http://www.wuerth.de/duebeltechnik)**

## OUR SERVICE FOR YOU:

### Hotline

Technical **HOTLINE** for fire safety systems

Phone: **0800 1813900**

e-mail: [brandschutz@wuerth.com](mailto:brandschutz@wuerth.com)

### Internet

Go online!

Get the latest information at:

[www.wuerth.de/brandschutz](http://www.wuerth.de/brandschutz)

- Systems / Products
- Approvals
- Installation instructions
- Tender texts

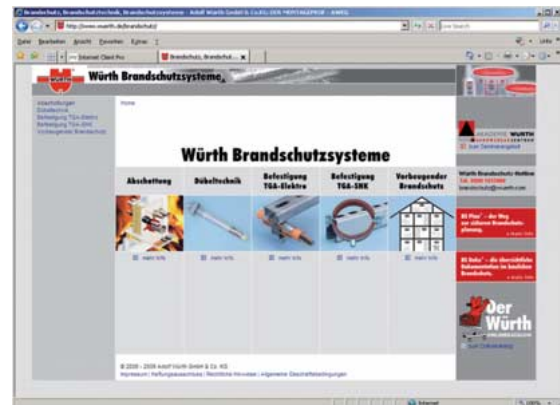

### Planning Aids

Quick and easy solutions for planning and calculation

#### Technical Software

Version **6.2**

Art. No. **0990 903 002**

#### Fire Protection Systems

Würth provides you with construction-approved system solutions for cable, pipe and joint partitions appropriate for the respective construction requirements in the field of structural fire protection pursuant to DIN 4102. The fire protection software provides you with all information on approvals, mounting instructions and tender texts. The software will also help you in calculating costs.



### On-site service

For large construction sites, our fire safety experts would be pleased to give you an on-site consultation. Make an appointment through our sales staff or our Technical Hotline.

### VARIFIX® Quick-Mounting System

Our extensive line of mounting rail products includes C-profiles for an extremely broad range of corrosion requirements. Wall brackets, cross-members and support frames can be simply and professionally produced with our extensive accessories.

Our user software provides you with support in planning and calculating the wide variety of available application options..

### Anchor Technology

Our comprehensive documentation, like the Würth Anchor Technology handbook, volumes 1 and 2, and our anchor measurement software with the latest methods for calculation help expand your professional knowledge. The simple, user-friendly user interface enables you to work quickly and intuitively. A single CD-ROM also provides you with all information, such as approvals, drawings, test certificates and other certificates..